



Powering Business Worldwide

Eaton Aerospace Operations
Conveyance Systems Division
Carter® Ground Fueling

SM64201

August 2007

Applicable addition manuals:

SM64019 2" Unisex Non-valved Coupling
SM44646 Hose End Regulator
SM349 MISC Miscellaneous Adapter Assemblies
SM40679 60427 Type QD Assemblies
SM61154 Dry Break Disconnect Assy
SM64015 Ball Valve
SM64254 Low Pressure Drop Dry Break

Maintenance Manual

Pressure Fueling Nozzle

Military D-1/D-2/D-3 Configurations

Model 64201

TABLE OF CONTENTS

	<u>PAGE</u>
1.0 INTRODUCTION	3
2.0 EQUIPMENT DESCRIPTION.....	3
3.0 TABLE OF OPTIONS AND ORDERING INFORMATION	4
4.0 SAFETY INFORMATION.....	6
5.0 SPECIAL TOOLS	7
6.0 DISASSEMBLY	8
7.0 INSPECTION.....	9
8.0 REASSEMBLY	10
9.0 TEST	11
10.0 ILLUSTRATED PARTS CATALOG	11
FIGURE 1 - 64201 WITH AVAILABLE OPTIONS	16
FIGURE 2 - BASIC NOZZLE PARTS BREAKDOWN	17
FIGURE 3 - HOLDING BRACKET & STIRRUP HANDLE INSTALLATION	18
FIGURE 4 - CONTINUITY CLIP INSTALLATION	19
FIGURE 5 - POPPET/COTTER PIN INSTALLATION	20
11.0 FAILURE MODES AND EFFECTS ANALYSIS.....	21

MAINTENANCE, OVERHAUL & TEST INSTRUCTIONS

CARTER PART NUMBER 64201 PRESSURE FUELING NOZZLE

1.0 INTRODUCTION

This manual furnishes detailed instructions covering the maintenance and overhaul of Carter® Ground Fueling part number 64201, Pressure Fueling Nozzle and its various options.

There are specific manuals available for nozzles that are qualified in accordance with SAE AS5877 (previously MIL-N-5877) and are designated D-1 and D-2 nozzles. These manuals are SM64201H and SM64201J respectively. There is also a

manual for the special nozzle used by the U.S. Army and Marine Corps, 64201CDK, manual SM64201CDK. These three manuals are more specifically written to cover the special options only and do not include all possible options as this one.

For the maintenance of options to the basic 64201 Pressure Fueling Nozzle, refer to Options Table, Section 3.0. This table will reference the service manual that should be used in the maintenance of each option.

2.0 EQUIPMENT DESCRIPTION

The Carter Ground Fueling part number 64201H, Pressure Fueling Nozzle is a 2-1/2 inch Pressure Fueling Nozzle that has been qualified to MIL-N-5877, Rev E and listed on that QPL as the D-1 nozzle. The 64201J is qualified to MIL-N-5877, Rev E and listed on that QPL as the D-2 nozzle. The mil-spec does not allow for all of the options shown in this manual but they can be procured as noted herein. The unit is designed to mate with adapters conforming to MS24484 or equivalent. The 64201H and J supersede the previously qualified 64349H and 64349J respectively. The 64201 is intended to replace the 64349 as the standard military nozzle provided by Carter. The 64201 Nozzle is completely different from the previous 64349 although all mating accessories currently furnished on the 64349 will work on the 64201.

The major differences lie in the simplification in the design to remove parts, especially moving ones on the outside of the units. In addition, the interlock system, previously depended upon pins to mate with the aircraft adapter, has been revised to eliminate the pins. The interlock system is a part of the replaceable nose seal and will be updated with each replacement of the nose seal. This interlock system will prevent any wear of the slots, since it does not even use the slots, on the adapter. This is a great advancement in safety and cost savings. Aircraft adapter slots will not become worn because of the interlock system on the Carter nozzle. Reducing the

wear of the slots reduces the chance of an accidental removal of the nozzle with it open causing a fuel spill.

NOTE:

The 64201 interlock system depends upon the three lugs on the adapter being within the industry standard wear limits. Wear limits are specified in SAE document ARP5298 – Adapter Wear Limits. A copy can be obtained from Carter distributors or through Carter direct. See note later in this section regarding potential problems if adapter lugs are worn.

Other features of the new 64201 include:

- A six-slot arrangement is included for installing the nozzle onto the aircraft making it easier to install.

NOTE:

If the 64201 has been installed on an adapter that has lugs with wear beyond the industry standard limits it may be difficult or impossible to install on the next aircraft. To fix, simply hold nozzle onto adapter and turn it counter-clockwise to move locking ring into the correct position, then turn it clockwise to install onto adapter.

If this occurs it is suggested that the aircraft operator be told of the worn

condition so that the adapter can be replaced at the earliest opportunity.

If the last adapter to which the nozzle was attached is on the refueling vehicle replace the adapter as soon as possible.

- Replaceable wear rings have been added to the various attaching options to improve the life of the swivel joint. (Note: All older options that attached to the previously qualified nozzle, 64349 will mate with the newer 64201).
- The opening lever or handle has been repositioned to make it possible to attach to all aircraft that have adapters designed and installed within the normal envelope and its operating direction has changed such that it is moved away from the aircraft, then opened, instead of into the aircraft as the older nozzles did. This makes it easier to open and close.

- Carrying handles on the 64201 are entirely of plastic eliminating the problems caused by the bending of the metal stick type handles used on previous Carter and competitor nozzles. They now act as shock absorbers when the nozzle is dropped, reducing the damage caused by mishandling.

The basic nozzle would be procured under the part number 64201, which includes the dust cap. Other options that are available to build a nozzle to specific specifications are listed in the table shown in Section 3.0. The exploded views in the figures at the end of the manual include the various options available.

All older accessories, except the Bonding Cable, option D, utilized on the previously qualified nozzles, 61429 and 64349 will mate to the new nozzle.

3.0 TABLE OF OPTIONS AND ORDERING INFORMATION

The following table should be used to determine the service manual to be used in the maintenance, repair or replacement of parts designated by option letters to the basic 64201 nozzle.

OPTION LETTER	PART NUMBER	SERVICE MANUAL	OPTION LETTER	PART NUMBER	SERVICE MANUAL
A	44373-40 (1)	SM61154	U	47234	SM64201
B	44373-60 (1)	SM61154	W	47063	SM349MISC
C	44373-100 (1)	SM61154	X	64019N	SM64019
D	44311	SM64201	2	43045-1	SM349MISC
E	41599	SM64201	2H, 2L, 2P	43108-1, -3 & -5	SM40679
F	44646-**(Note 2)	SM44646	2K, 2M, 2S	47524, 47525 & 44771	SM64201
G	47449	SM64201	3D, 3DE, 3H, 3P	64015	SM64015
H	44327	SM349MISC	4	41600	SM60129-1
J	44326	SM349MISC	5	64020N	SM64020
K	44325	SM349MISC	6, 6H, 6L, 6P	61154	SM61154
L	47536	SM64201	6Y, 6YH, 6YL, 6YP	64254	SM64254
M	47488	SM64201	7, 7H, 6L, 6P	61154	SM61154
N	47566	SM349MISC	8, 8H, 8L, 8P	61154	SM61154
P	47537	SM64201	9	44362	SM348MISC
R	47232	SM64201	9H, 9L, 9P	43108-1 through -6	SM40679
S	47401	SM64201			

Notes: 1. Standard Screen shown, some options utilize 41767-** or 47115-** in lieu of 44373-**. ** Indicates that the mesh size must be added to get a complete part number, e.g. 44373-100. See SM40679 or SM64019 respectively for further information of these two screens.

2. The part number shown is not complete and must include the spring setting (35, 45 or 55) to achieve a complete number.

The part number of a complete nozzle consists of four basic parts as illustrated below.

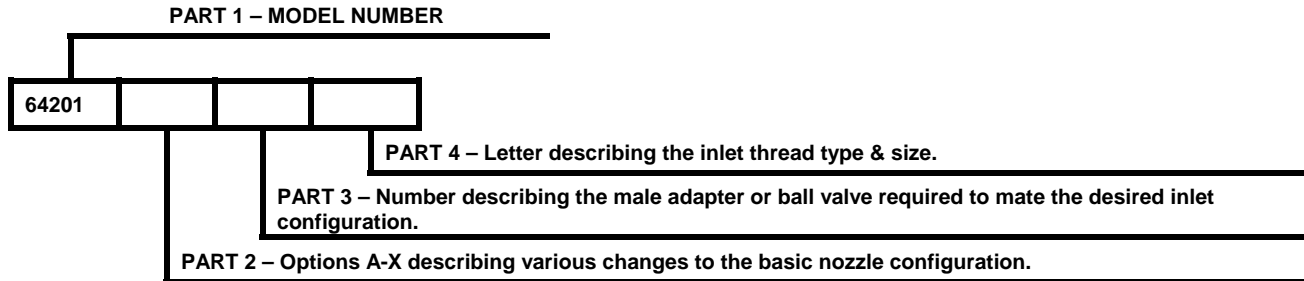

PART 2

The following options may be added as Part 2 of the part number as indicated above to order a unit to meet your requirements:

OPTION LETTER	DESCRIPTION	OPTION LETTER	DESCRIPTION
*A	Adds 40-mesh Screen	K	Adds QD with 2" Female Camlock Inlet
*B	Adds 60-mesh Screen	L	Changes Stick Handles to Circular Handle, extended length (for use with Hose End Regulator)
*C	Adds 100-mesh Screen	M	Changes Stick Handles to Circular Handle
D	Adds Commercial Bonding Cable	N	Adds Universal (D-1/D/2) Inlet
E	Adds Vacuum Breaker	P	Adds 45° Elbow inlet (modified flange to mate with Flight Refueling Male QD Adapter)
F3	Adds 35 psi Hose End Regulator	Q	Adds Gammon Samping QD
F4	Adds 45 psi Hose End Regulator	R	Adds Nozzle Stowage Bracket
F5	Adds 55 psi Hose End Regulator	S	Holder Bracket (not needed with Option U)
G	Adds Military Bonding Cable	U	Changes Stick Handles to Stirrup Handles
H	Adds 45° Elbow inlet with Military Flange (D-1)	W	Adds MIL-C-24356 Coupling to Inlet
J	Adds Straight Inlet with Military Flange (D-2)		

* Options A, B & C only available when a male half, unisex coupling or a ball valve from Part 3.
Option A not available with Option 2, 9 or M (C only available on M).

PART 3

One of the numbers below must be included, as Part 3, as indicated above, to specify the type of inlet configuration desired. The nozzle may be ordered with the inlet terminating in an adapter half only if desired. In this case leave Part 4 blank. If a female half, either quick disconnect, ball valve or dry break of some configuration is desired, Part 4 must be completed.

OPTION LETTER	DESCRIPTION	OPTION LETTER	DESCRIPTION
2	Adds male half adapter to options H or J to connect to 60427 type quick disconnect.	6	Adds military male adapter half to mate 61154 dry break disconnect.
3	Adds ball valve to options H or J. See SM64015 for details concerning the operating handles and defueling key.	6Y	Adds male adapter half to mate 64254 Low Pressure Drop Dry Break.
3D	Adds option 3 with Glass Inspection Cap	7	Adds male adapter half to mate 61154 Dry Break when regulator is used.
3E	Adds option 3 with Drag ring	8	Adds male adapter half to mate 61154 Dry Break when regulator is not used.
3DE	Adds options 3, 3D and 3E above	9	Adds male adapter half to mate with 60427 style quick disconnect.
4	Adds Flight Refueling QD adapter (used with Option P Elbow and/or flanged style Hose End Regulator)	X	Adds Tan Non-valved Unisex Coupling to Inlet
5	Adds Valved Unisex Coupling to Inlet		

PART 4

One of the following letters must be included as Part 4 as indicated above to specify the inlet thread and size:

OPTION LETTER	DESCRIPTION	OPTION LETTER	DESCRIPTION
H	Inlet thread - 2½" NPT	P	Inlet thread - 2" NPT
K	Adds 4" Male Camlock	*Q	Adds Dust Cap or Plug to Camlock Inlet
L	Inlet thread - 3" NPT	**S	2" Female Camlock Inlet
M	Adds 4" Female Camlock		

* Available only with options K (part 2 or 4) or M or S (part 4) only.

** Adds to option 2 only.

Example: 64201 - Standard D-1 Nozzle with 6-bolt inlet flange and 45° inlet elbow.

64201CF5J3DEH - D-2 Nozzle with 55 psi regulator and ball valve with 100-mesh strainer, ball valve with glass inspection port, drag ring and 2½" NPT inlet.

4.0 SAFETY INFORMATION

The 64201 Nozzle is designed to overcome the interlock wear problems associated with previous Carter and Whittaker nozzles. The interlock system is not dependent upon pins in the nozzle engaging the slots in the aircraft adapter. The interlock system in the 64201 is internal and involves the body of the nozzle and the basic aluminum part of the nose seal. The interlock system is refreshed with each replacement of the nose seal.

Safety is still a major concern when handling the nozzle. Certain areas of the nozzle should be inspected periodically to assure that the unit is safe to use.

4.1 OPERATING LEVER STOPS

The operating Lever (on-off control) (27) opening and closing is controlled by mechanical stops built into the Body (6) of the unit. This stop is also utilized as a wear strip to prevent wear of the Screws (26) that retain the Lever onto the nozzle. The Knob (38) is a sacrificial part that is also used for wear prevention.

Prior to each fueling of an aircraft it is recommended that the operator check the stop for the Lever to be sure it is functioning correctly. If the stop portion of the Body is worn down to where the

Screws are being worn, then the nozzle should be replaced.

If the Knob is worn badly such that the Screws are in danger of being worn then the Knob should be replaced prior to the next refueling.

4.2 LEAKAGE DURING REFUELING

Any leakage from the nozzle or the mating joint with the aircraft should be cause for stopping the operation and the nozzle should be replaced. The following paragraphs describe the possible leakage paths with the 64201.

4.2.1 NOSE SEAL LEAKAGE

During the refueling operation the operator should note any leakage from any portion of the nozzle. Nose Seal (21) leakage will be apparent if there is fuel dripping or otherwise present at the connection between the nozzle and the aircraft adapter. If any leakage is present during refueling, the operation should be stopped and the nozzle replaced. There are two possible leak paths, the Nose Seal (21) or the O-ring (23) around the Nose Seal. The nozzle should be overhauled to prevent future leakage.

4.2.2 OPERATING LEVER LEAKAGE

If leakage is present from the area of the operating Lever (27) then the O-ring (35) will have to be replaced. Refueling should not be continued if such leakage is present.

4.2.3 SWIVEL JOINT LEAKAGE

There are two possible leak paths from the swivel joint of the nozzle, from the O-ring (45) and the seal in the mating part or from the Gasket (2). The latter is highly unlikely. If leakage is present, stop refueling and replace the nozzle.

4.2.4 NOZZLE BODY PLUGS/ACCESSORIES

The 64201 has two accessories ports in the side of the body. These are shipped from the factory with pipe Plugs (5) installed. Other accessories are available either from Carter or other manufacturers that can be installed in one or both ports. Tightening the plugs or the accessory can normally stop leakage from either of these ports. Do not refuel with leakage from these devices.

4.2.5 OPERATING NOTES AND WARNINGS

The nozzle was designed to be operated in a fully open position or to be closed. No middle point is provided in the design.

STRONG WARNING!

The nozzle was not designed to be used with the operating handle in a partially open position, as is the practice of some segments of the services. The handle is not a flow indicator and operating the nozzle in such manner is strongly not recommended as being a safe practice. If the interlock system is worn the nozzle could be removed from the aircraft in an open position causing a spill.

4.2.6 THERMAL EXPANSION

The nozzle is designed for operation up to and including pressure of 180 psi. (Actually the nozzle will withstand and is tested to 300 psi but the military specification has a burst pressure rating of 180 psi. Burst pressure is the pressure that the nozzle can withstand without structural damage but need not be operable after being subjected to that pressure). Pressures caused by thermal changes, thermal expansion can rise dramatically. A temperature change of just 30 degrees in a closed nozzle can raise the pressure within the unit to over 500-psi. The 30-degree temperature change can be from -10° to +20° F or any other change of this magnitude. The temperature does not have to be high at all to cause the pressure to increase.

WARNING!

Do not leave the nozzle full of fuel and in a completely closed off environment if the temperature is rising. If stored on its hose the hose will offset some of the temperature increase. A thermal relief system should be employed if the nozzle is to be stored in such a condition.

WARNING!

The use of unisex couplings with a valve or any other valve on the inlet of the nozzle is not recommended and is provided only at the request of the customer. If used and the nozzle/unisex coupling is removed from the hose for storage, drain the nozzle of liquid before storing.

5.0 SPECIAL TOOLS

The following special tools are recommended for proper repair and or overhaul of the nozzle:

- S204451 - Standard three lug bayonet adapter flange or equivalent. (This item should have a handle of a sort mounted to

two of the mounting holes to assist in turning it onto the nozzle).

- 6958CG or 6958CH Adapter or equivalent.
- 64201STI Poppet Adjustment Gauge
- 61607 Ball (10 & 11) Assembly Tool

- WL4680 Torque Wrench or Standard torque wrench is required for some disassembly and re-assembly. WL4680 includes several sockets for special usage on Carter products.
- Vernier calipers should be used to inspect the various holes and outside diameters in Section 7. If desired commercially

available go – no go pins can be purchased for this purpose from various sources.

The above items are available from your Carter distributor or other commercial sources.

6.0 DISASSEMBLY

- 6.1 Remove nozzle from end of hose at quick disconnect. Refer to appropriate service manual depending upon type of swivel disconnect utilized.

SERVICE MANUAL	DESCRIPTION
SM61154	Dry Break Quick Disconnect
SM64015	Ball Valve
SM349MISC	Miscellaneous Adapters
SM40679	60427 type QD
SM64019	Unisex Coupling – Non-valved.
SM64020	Unisex Coupling – Valved
SM64254	Low Pressure Drop Dry Break

- 6.2 Screw (1) is a self-locking type screw that utilizes a nylon insert in the threads to affect the resistance required to provide the locking.

Note: Early versions of the nozzle may use a different Screw (1) that has a smaller thread. This thread in the Body (6) will not accept the Ball Tool 61607.

They are designed to be reused a number of times before losing their locking affectivity. Using a torque wrench, remove Screw (1) and Gasket (2) from lower half of Body (6), measuring the torque during removal. If the torque is less than 9.5 in lbs. (0.11-m kg) discard the screw and replace it with a new one during reassembly. Remove Balls (3), 39 each, from unit by use of the Ball Tool or by hand. On newer nozzles the Ball Tool can be used. If Ball Assy Tool 61607 is available, screw it into the boss from which Screw (1) was removed. Hold the nozzle such that the Tool is below the nozzle and rotate the accessory attached to the nozzle until all Balls (3) have been captured in the Tool. The correct amount of Balls (3) will be captured when the level of Balls (3) reaches the line scribed on the tube of the Tool. If the balls are to be removed by

hand (without the tool) hold the bolt hole vertical (pointed down) and allow all ball bearings to fall through the bolt hole. Catch all balls in a container. Some rotation between the Body (6) and the attached accessory may be required to allow 39 Balls (3) to fall out of hole. Remove accessory (refer to appropriate Service Manual). If Clip (4) is to be replaced, use a pair of needle nose pliers to grasp the existing part and pull it from the hole in the Body (6). See Figure 4. Clear the hole of any debris.

Remove Gasket (2) from Screw (1) and discard.

Remove O-Ring (45) from internal groove in the inlet of the Body (6) and discard.

Inspect the Ring (46); remove if necessary, for wear or damage. If not worn then leave it in place.

- 6.3 To remove the Cover (44) or Bonding Cable (67 or 79) it is necessary to remove the appropriate Grip (43) or Handle Assembly (72). If the Cover (44) and the Cable (67) are in good condition it is not necessary to remove either at this time. Leave them attached to the Body (6). If they are to be removed, the Screw (41) should be removed with a torque wrench and the removal torque measured. This screw is a self-locking type and is designed to be reused several times before losing its locking capability. If the torque is less than 6.5 in-lbs. (0.078-m kg) discard it and replace it during reassembly.
- 6.4 Remove the Bumper (7) by prying up the thinner end with a wide bladed screwdriver and peeling it off the Body (6). If worn to a point that it no longer protects the Body (6) discard and replace.
- 6.5 If the interlock stowage Holder (69) is present inspect to determine if it needs replacing. If it needs replacing remove

- Screws (70) and Washers (71). Discard Holder (69).
- 6.6 Remove the six Screws (8) and Retainer (9).
- 6.7 Using an S204451 Adapter or any other standard 3-lug bayonet adapter, connect the nozzle to it and rotate nozzle clockwise to the open position. Remove nozzle off of adapter.
- 6.8 Remove Lock Plate (10) and four Springs (11).
- 6.9 Rotate operating Arm (27) to open nozzle Poppet (20). Remove Cotter Pin (12) from the assembly and discard. Remove assembly. Check to see that assembly will swivel freely on Insert (18). If not then further disassembly is needed. If further disassembly is necessary continue on to 6.9.1 otherwise go to 6.10. Note: Unless another problem with the assembly has been noted do not disassemble it further.
- 6.9.1 Remove Retaining Ring (14) using a small bladed screwdriver to capture the end of the ring and peel it out of the Poppet (20).
- 6.9.2 Remove Thrust Washers (15), 22 Balls (36). Discard Thrust Washers (15). The balls are tiny so put them in a container for cleaning and future use.
- 6.9.3 Remove Insert (18) and Thrust Washer (19). Discard Thrust Washer.
- 6.10 Pull Nose Seal (21) from unit. If it has been in use for a year or more or if the rubber portion is damaged it should be discarded. This also refreshes the interlock system of the nozzle.
- 6.11 Remove and discard Thrust Washers (22) and O-ring (23).
- 6.12 Remove the Plug (5) or any accessory from Port A (Figure 2). This will provide access for later removal of other parts of the unit.
- 6.13 Remove and discard Cotter Pin (24). Rotate Link (28) to gain access to Pin (29) with an Allen wrench. Hold Pin (29) in place and unscrew Nut (25). Remove Pin (29). (Note that older links will be red in color while the newer ones will be natural stainless steel in color. Both are fine to use.)
- 6.14 The Shaft (32), Washer (30), Pin (31) and Link (28) can now be removed from the Body (6).
- 6.15 Remove Screws (26) and Arm (27) with parts holding Knob (38) in place. Put aside for later disassembly. Pull Shaft Assembly (33) from Body (6). Note on older nozzles Bearing (36A) may not be present. Bearing (36) and Thrust Washer (34) may be used in lieu of Bearing (36A) The single Bearing (36A) is the latest configuration. The Bearing (36A) is flanged and must be removed from the inside of the Body (6). Regardless of which is present remove and discard the bearing and thrust washer if present.
- 6.16 The Bearing (36) Washers (34) and O-ring (35) can now be removed from the outside of the Body (6). The Bearing (36) may be difficult to remove. Care should be taken to not damage the bore of the Body (6) especially if a sharp tool is used for removal. It is recommended that a Teflon rod of $.690 \pm .002$ inches diameter ($17.526 \pm .051$ mm) be used for this purpose. Discard all of the parts removed from the shaft bore.
- 6.17 Remove Screw (37), Nut (40) and Washer (39) to replace Knob (38).
- 6.18 Note: Do not remove Pin (6A) from Body (6) for any reason unless it is damaged and is to be replaced. This is an integral part of the interlock system.
- 6.19 On option E - remove the Vacuum Breaker (55) only if replacement is required. The Vacuum Breaker (57) is not economical to repair and should be replaced, if needed, as a complete assembly. **Attempts to repair this unit may result in fuel spills.**
-

7.0 INSPECTION

It is recommended that all O-rings (23), (35) & (45), Gasket (2), Thrust Washers (19), (22) & (34), Nose Seal (21) & Cotter

Pins (12) & (24), Knob (38) and Bearings (36) and (36A) be replaced upon every overhaul. It may also be necessary to

replace Grip (43) and Bumper (7) depending upon wear. If Poppet assembly has been disassembled then Thrust Washers (15) and (19) should also be discarded. Inspect all metal parts for dings, gouges, abrasions, etc. Use 320 grit paper to smooth and remove sharp edges. Replace any part with damage exceeding 15% of local wall thickness. Use alodine 1200 to touch up bared aluminum. Precisely measure the following items. Replace any part that exceeds the identified maximum or minimum wear limits:

- Both holes in item 28 Link - .196 inch (4.98 mm) diameter max. & .318 inch (8.08 mm) diameter max.
- Hole in item 32 Shaft – .198 inch (5.03 mm) diameter max.
- Bearing diameter of item 31 Pin - .186 inch (4.70 mm) diameter min.
- Shaft of the Shaft Assembly (33) – No part of it shall be less than .621 inch (15.77 mm).
- Ring (10) – Visually check for wear on the corners of the tabs protruding from the outer diameter. If the corners are rounded off, replace this part.
- Wire Race (45) – If the diameter of the wire is less than 0.075 inches (1.905 mm) at any place around the major diameter or there are obvious worn or flat spots replace it.
- Retainer (9) – Carefully inspect for any cracks in the part. Replace as needed.
- Inspect Holder (69) if present for wear that will cause the item to be non-functionable.

8.0 REASSEMBLY

8.1 Reassemble in reverse order of disassembly (Refer to Figure 2), observing the following:

8.1.1 Make certain all components are clean and free from oil, grease, or any other corrosion resistant compound on all interior or exterior surfaces. Wash all parts with cleaning solvent, and dry thoroughly with a clean, lint-free cloth or compressed air.

WARNING:

Use cleaning solvent in a well-ventilated area. Avoid breathing of fumes and excessive solvent contact with skin. Keep away from open flame

DO NOT use any form of grease on Balls (3) and be certain to install proper number of balls in each hole of Body (6) and collar assembly. The use of Tool 61607 will facilitate the counting and assembly of the Balls (3) back into the unit. Also make sure that Clip (4) is installed properly to maintain continuity through the unit. Refer to Figure 4 for installation information.

NOTE: A light coat of petroleum jelly can be applied to all o-rings, springs, and non-locking screws for ease of installation.

8.1.2 When installing Pin (31) in place it can be inserted into the Link (28) and Shaft (32) outside of the body and held in place by a small piece of tape while assembling into the unit. Be sure to remove the tape afterwards. One can also hold the pin in place with one finger while inserting.

Reinstall the Plug (5) after completing assembly of the internal parts of the nozzle.

NOTE: The Plug (5) has a sealant already in place and can be reused for several times. If Teflon tape is used on reinstallation, do not utilize more than 1 1/2 wraps of tape. Excessive use of tape could lead to the cracking of the Body (6).

8.1.3 If the Poppet assembly was disassembled a coating of petroleum jelly and the use of tweezers to install the small Balls (16) will make the job easier. There are 22 of the balls.

8.1.4 When reinstalling the Nose Seal (21) care should be taken to position it with two lugs placed within the large grooves in the

- Body (6) and the flat part of the tongue of the nose seal up against the Crank (28) when the operating Arm (27) is in the nozzle open position. Seat the Nose Seal (21) into the Body (6).
- 8.1.5 The standard poppet adjustment tool used on previous Carter nozzles will not work on the 64200. A good starting point in adjusting the poppet is to bottom the poppet onto the Shaft (32) with the nozzle open, then back it out approximately 1.75 turns. Once the adjustment is made, rotate the Poppet toward the tightening direction until the next slot in the Poppet (20) is in line with the hole in the Shaft (32). Insert the Cotter Pin (12) but do not bend the ends at this time. Close the nozzle and measure the distance from the top face of the poppet to the top face of the exposed Body (6). It should be 0.491 ± 0.010 (12.47 \pm 0.25 mm). If not within this range remove the cotter pin and readjust until the correct dimension is achieved. Then bend over the ends of the Cotter Pin (12) to retain in place in accordance with Figure 5. Note it is important that the correct length of Cotter Pin (12) is utilized for the assembly.
- 8.1.6 Use the adapter to rotate the nose seal counter-clockwise to the nozzle-closed position.
- 8.1.7 Install Plate (10) and Springs (11) noting that the four indentations on the plate must fit into each of the four springs.
- 8.1.8 Hold the Plate (10) in position and install the Retainer (9) with the six Screws (8). These screws should be torqued to 50 in-lbs. (0.58 m-kg).
- 8.1.9 Reinstall the Bumper (7).
- 8.1.10 If the Grip (43) or Handle (90 or 91) requires replacing due to wear or the replacement of the Cover (44), the new Grips (43) or Handle (90 or 91) shall be reinstalled using the appropriate screws and washers.
- 8.1.11 Note that Bearing (36A) must be installed into the handle shaft hole in the Body (6) from the inside and must be seated in place prior to installing the Crank Shaft Assembly (33).

9.0 TEST

- 9.1 The following test procedures will be accomplished after overhaul: evidence of binding or excessive force required for valve actuation.
- 9.2 Test conditions
- Test media shall be JP-4, Jet A or odorless kerosene, commercial solvent 140.
- 9.3 Functional Test
- 9.3.1 The nozzle shall be inserted and locked into a test adapter, Carter® 6958CG or CH or equivalent and the nozzle valve actuated by use of the crank Lever (14) from the fully closed to fully open position a minimum of five times. There shall be no
- 9.4 Leakage Test
- 9.4.1 With the nozzle outlet in the normal open position and the test adapter outlet closed, pressurize the inlet to five psi and hold for one-minute minimum. There shall be no evidence of external leakage from the nozzle.
- 9.4.2 Repeat the leakage test at 60 psi and 120 psi.
- 9.4.3 Close and disengage the nozzle and repeat 9.4.1 and 9.4.2.

10.0 ILLUSTRATED PARTS CATALOG

Table 1.0 tabulates the parts and sub-assemblies comprising the 64201 Pressure Fueling Nozzle. The item numbers of the table are keyed to the exploded views of the nozzle diagrammed in Figures 1 through 4.

TABLE 1.0

The following table presents all items used in the basic 64201 Nozzle and its possible options. The column headed by "Spares/10 Units/Yr." represents our best estimate as to the spare parts needed to support 10 basic nozzles (and some of its options) for a one-year period. All items that show a need for 10 or more items are provided in the basic overhaul kit.

Item No.	Part Number	Description	Qty/ Assy	Used on Option	Spares/10 Units/Yr.
1	220484	Screw	1	All newer nozzles	-10
	221107	Screw	1	Earlier nozzles	-
2	MS29512-03	Gasket	1	All	10
3	221075	Ball	39	All	-
4	209853	Clip, continuity	1	All	10
5	210388	Plug	2	All except E	-
6	47367	Body Assembly	1	All	-
6A	.156-.500LDP	Pin (Not a spare part - not shown)	1	All	-
6B	47367	Body (Not a spare part - not shown)	1	All	-
7	220999	Bumper	1	All	10
8	NAS1351-3-8P	Screw	6	All	-
9	220995	Retainer	1	All	-
10	221120	Plate, Interlock	1	All	-
11	C0240-020-0810S	Spring, Interlock	4	All	-
12	GF24665-368	Cotter Pin	1	All	10
13	221617	Ring, Backup	1	All	10
14	RRN-100S	Ring, Retaining	1	All	-
15	91124A111	Washer, Thrust	2	All	10
16	GF19060-508	Ball	22	All	-
17	Left intentionally blank				
18	221008	Insert, Poppet	1	All	-
19	95606A260	Washer, Thrust	1	All	10
20	221010	Poppet	1	All	-
21	47368	Nose Seal, Interlock Assembly	1	All	10
22	221011	Washer, Thrust	2	All	20
23	201201-148	O-ring	1	All	10
24	GF24665-1013	Cotter Pin	1	All	10
25	GF320C4	Nut	1	All	-
26	221012	Screw	3	All	-
27	221017	Arm, Crank	1	All	2
28	220994	Link	1	All	-
29	221014	Pin, Crank	1	All	-
30	5702-240-30Z2	Washer	1	All	-
31	D9-437	Pin	1	All	-
32	221005	Shaft	1	All	-
33	47209	Shaft Assembly, Crank	1	All	-
34	95606A210	Washer, Thrust	2	All	20
35	MS29513-208	O-ring	1	All	10
36	10L12-D	Bearing	1	All	10
36A	10L14-F	Bearing, Flanged	1	All	10

Item No.	Part Number	Description	Qty/ Assy	Used on Option	Spares/10 Units/Yr.
37	GF24693C296	Screw	1	All	2
38	221019	Knob	1	All	10
39	221015	Clamp	1	All	-
40	90045A450	Nut	1	All	2
41	GF16997-97L	Screw	1	All except U	-
42	GF960-616	Washer	1	All except U	-
43	221020-1	Grip, standard	2	All except U	10
44	221026	Cover, Dust	1	All	5
45	M25988/1-235	O-ring	1	All	10
46	220893	Ring, Wear	1	All	2
47	44646-*	Regulator (Note 1)	-	F3, F4, F5	-
48	44326	D-2 Flanged Inlet (Note 4)	-	J	-
49	44327	D-1 Flanged Inlet (Note 4)	-	H	-
50	44663	Adapter - 61154 (Note 2)	-	6	-
50A,B,C	41767-**	Screen Assy (Note 2)	-	A, B, C	-
	44373-**		-	A, B, C	-
	47712-**		-	A, B, C	-
	47115-**		-	A, B, C	-
51	43045-1	Adapter - Option 2 (Note 4)	-	2	-
52	43108*	QD, Female Half (Note 3)	-	9H, L, P	-
53	44325	QD, 2" Female Camlock (Note 4)	-	K	-
54	41599	Vacuum Breaker	-	E	-
55	47063	MIL-C-24356 Inlet (Note 4)	-	W	-
56	64201	Nozzle	-	All	-
57	44697	Short Male Adapter Assy (Note 2)	-	7	-
58	44701	Long Male Adapter Assy (Note 2)	-	8	-
59	61154H	Dry Break Assy, 2½ NPT (Note 2)	-	7H	-
60	61154L	Dry Break Assy, 3 NPT (Note 2)	-	7L	-
61	61154P	Dry Break Assy, 2 NPT (Note 2)	-	7P	-
62	64019N	Unisex Coupling (Tan) (Note 2)	-	X	-
63	64015*	Ball Valve (Note 6)	-	3H, 3L, 3P	-
64	GTP-235-3/8	Gammon Sampling QD	-	Q	-
65	44362	Male Adapter Assy (Note 4)	-	9	-
66	44771	Female Half Inlet Assy (2" Camlock)	-	S	-
67	47235	Cable, Bonding	-	D	-
68	47401	Holder Bracket Assembly	1	R	-
69	221071	Hanger, Nozzle	1	R	-
70	GF16997-60L	Screw	2	R	-
71	GF960C416	Washer	2	R	-
72	47234	Stirrup Handle Assembly	1	U	-
73	221001	Handle	1	U	4
74	221003	Support	4	U	-
75	GF16997-103	Screw	2	U	-
76	5851-17	Washer	2	U	-

Item No.	Part Number	Description	Qty/ Assy	Used on Option	Spares/10 Units/Yr.
77	47401	Bracket Holder Assembly, 45°	1	S	-
78	221534	Hanger	1	S	4
70	GF16997-60L	Screw	2	S	-
71	GF960C416	Washer	2	S	-
79A	47449	Military Bonding Cable Assembly	1	G	-
79B	47607	Grounding Cable Assembly	1	V	-
80	64020N	Unisex (valved) – 2" Tan	1	5	-
81	GF27029-11-TN	2" Plug, Camlock	1	K (part 2), Q (part 4)	-
82	47525	4" Female Camlock Inlet	1	M	-
83	47524	4" Male Camlock Inlet	1	K (part 4)	-
84	GF27028-17-TN	4" Cap, Camlock	1	KQ (part 4)	-
85	47566	Universal Inlet (D-1/D-2)	1	N	-
86	GF27029-11-TN	2" Plug, Camlock	1	S (part 4)	-
87	GF27029-17-TN	4" Plug, Camlock	1	M (part 4)	-
88	47537	45° Elbow, flanged – modified for use with flanged regulator or Option 4 adapter	1	P	-
89	41600	Flight Refueling Adapter	1	4	-
90	47488	Circular Handle	1	M	-
92	207816	Grip, Circular		M	-
93	221687	Handle	2	M	-
94	GF960-616	Washer	2	M	-
95	GF16997-97L	Screw	2	M	-
91	47536	Circular Handle, Extended Length	1	L	-
92	207816	Grip, Circular	1	L	-
94	GF960-616	Washer	4	L	-
95	GF16997-97L	Screw	2	L	-
96	GF16998-79	Screw	2	L	-
97	GF16998-46L	Screw	2	L	-
98	GF21083C6	Nut	2	L	-
99	221689	Bracket	2	L	-
100	221688	Support, Bracket	1	L	-
101	GF21083C4	Nut	2	L	-
102	47633	Military Male Half Assy – Low DP DB (Note 8)	1	6Y	-
103	47584-1	Female Half Assembly – Low DP DB – 2" NPT	1	6YP	-
104	47854-2	Female Half Assy – Low DP DB – 2 1/2" NPT	1	6YH	-
105	47584-3	Female Half Assy – Low DP DB – 3" NPT	1	6YL	-
106	210641	Safety Clip	1	-	-
107	64051DE	Uni-Sex Coupling, non-valved, non- swivel	1	-	-

Item No.	Part Number	Description	Qty/ Assy	Used on Option	Spares/10 Units/Yr.
	KD64201-1	Kit – Normal Overhaul Parts, Consists of Items 1, 2, 4, 7, 12, 15, 19, 21, 22, 23, 24, 34, 35, 36, 36A, 38, 43, 45, M25988/1-040 O-ring, & 207807 Seal.	-	-	-
	KD64201-2	Kit to make a major overhaul when used with a –1 kit. Consists of KD64201-1 plus items 27, 37, 40, 44 & 46.	-	-	-
	KD64201-3	Kit to overhaul the 64254 Dry Break.	-	-	-

Notes:

1. Refer to SM44646 for detail information. * Add pressure rating to part number to complete it.
2. Refer to SM64019, SM64020, SM44315, SM61154, SM40679, SM64254 or SM64015 for detail information. ** Add screen mesh size to part number to complete it.
3. Refer to SM40679 for detail information.
4. Refer to SM349MISC for detail information.
5. All part numbers beginning with "GF" are interchangeable with those beginning with either "AN" or "MS". If three numbers follow the "GF" it is interchangeable with an "AN" part; otherwise it is interchangeable with an "MS" part of the same number.
6. Refer to SM64015 for detail information.
7. KD64201-1, -2 and -3 may be combined to obtain one kit to achieve the task noted. Example KD64201-1-2 – Kit that includes both the -1 and -2 kits.
8. Refer to SM64254 for detail information.

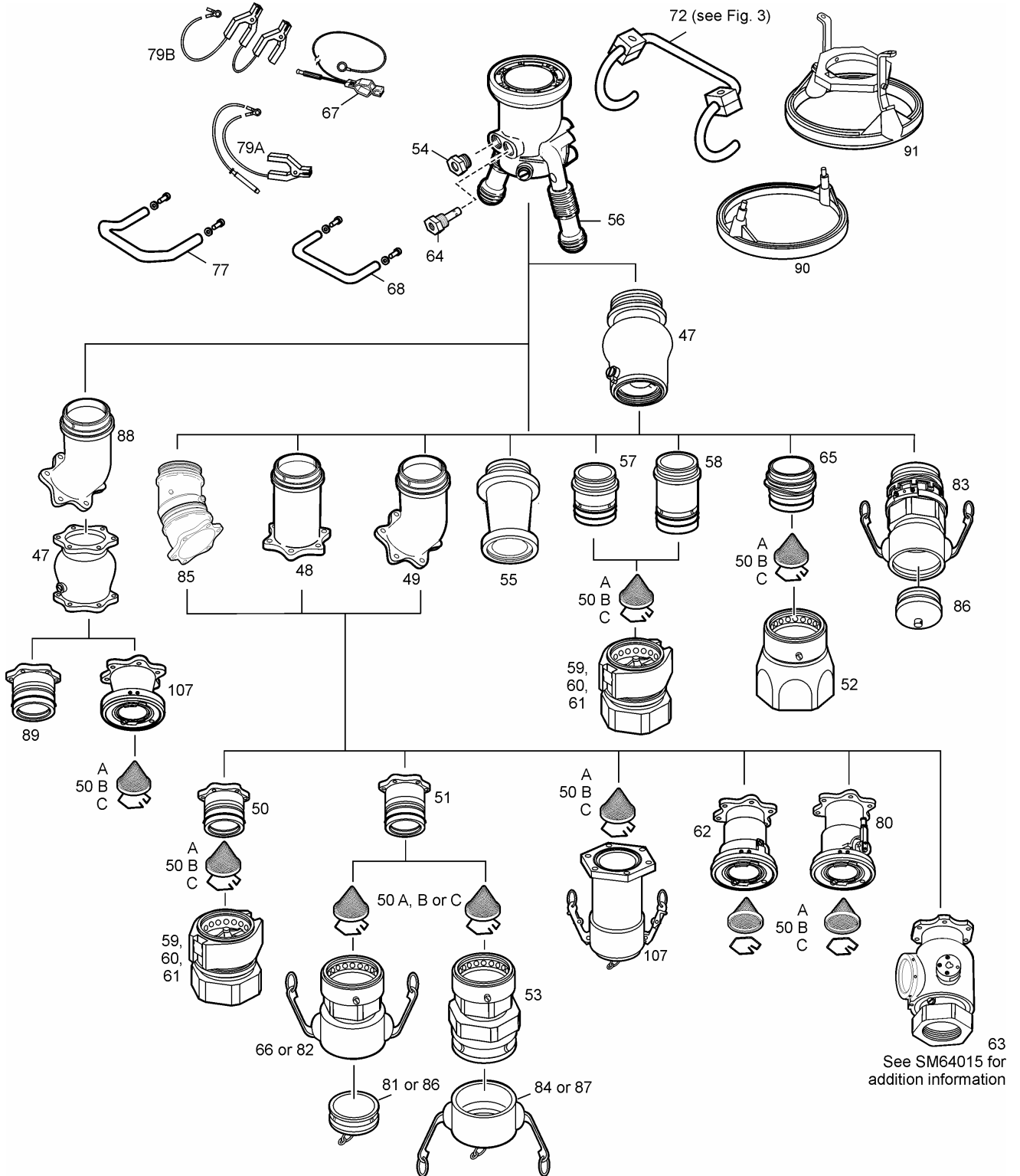

FIGURE 1

64201 WITH AVAILABLE OPTIONS

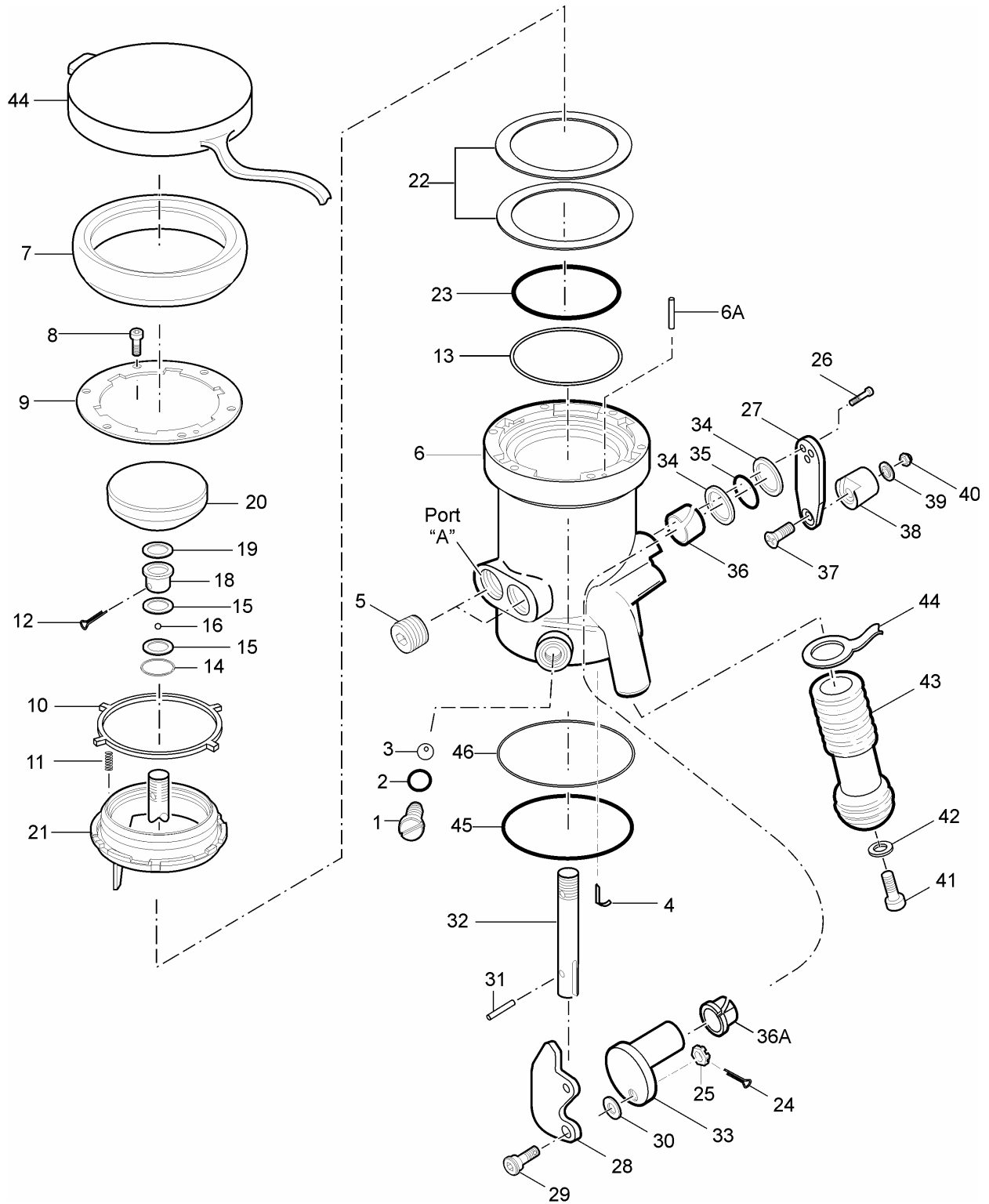

FIGURE 2

64201 BASIC NOZZLE PARTS BREAKDOWN

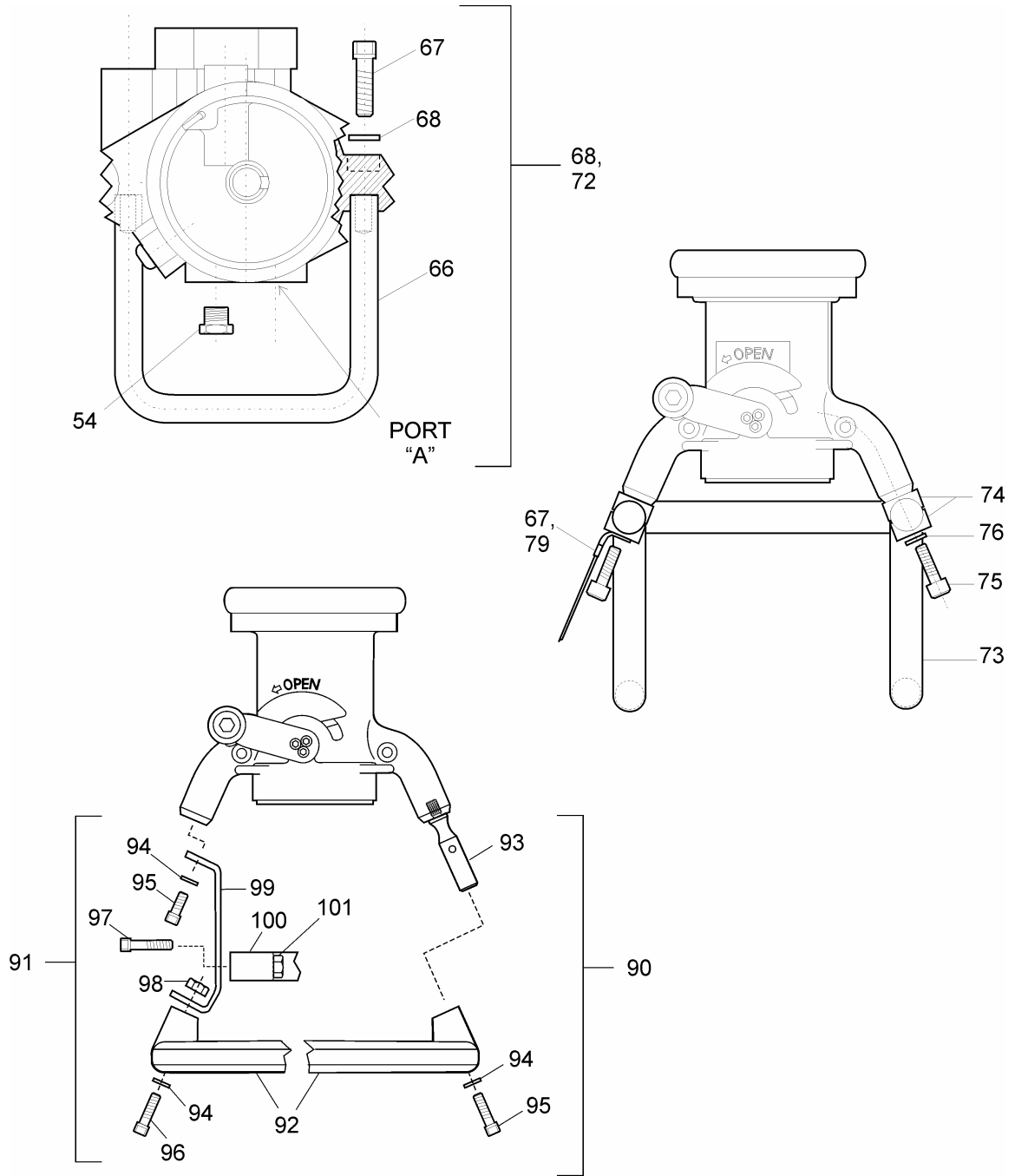

FIGURE 3
Holding Bracket, Circular and Stirrup Handle Installation

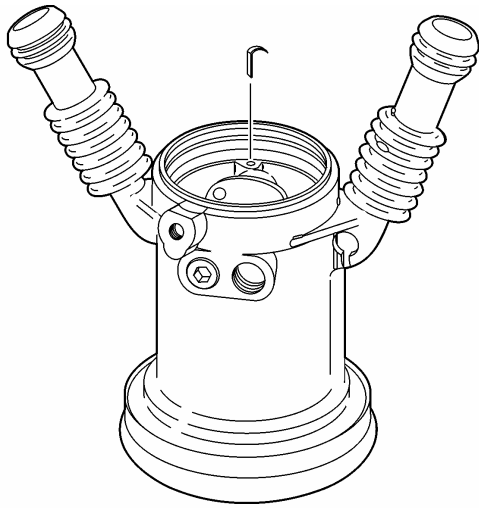

FIG. 4A
CONTINUITY CLIP INSTALLATION (4)

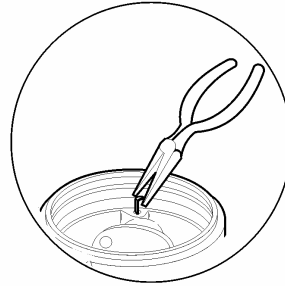
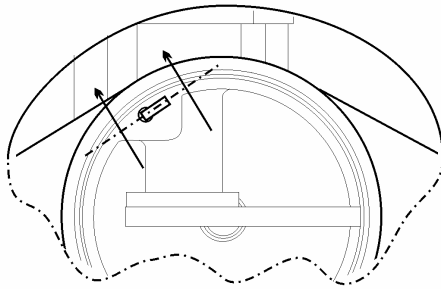

FIG. 4B
REMOVING CLIP (4)



OVERHEAD VIEW

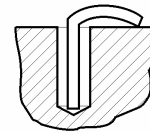

FIG. 4C
CORRECT CLIP INSTALLATION (4)

FIGURE 4
CONTINUITY CLIP INSTALLATION

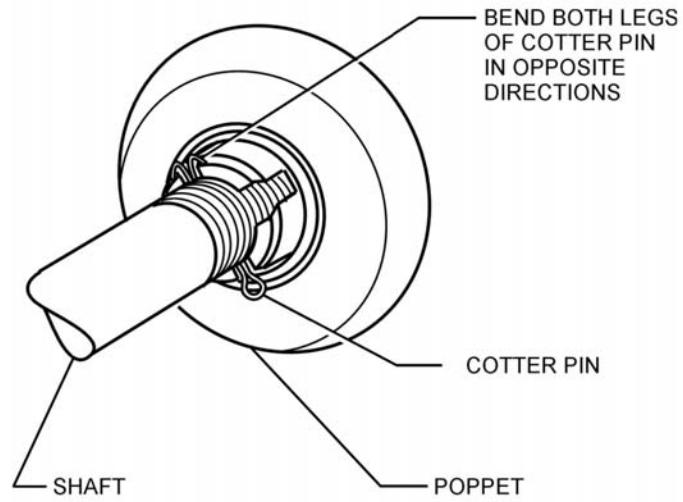

FIGURE 5

POPPET/COTTER PIN INSTALLATION

11.0 FAILURE MODES AND EFFECTS ANALYSIS

11.1 Notes that apply to this analysis:

- A. Hazard category, hazard probability, and real hazard index (RHI) are defined herein.
- B. "Visual inspection" means examining the nozzle for obvious cracks, damage, and broken lugs, prior to initial pressurization.
- C. "Pressure test prior to use" means pressurizing the nozzle and attached hose to operating fuel pressure, then removing pressure, prior to aircraft arrival.
- D. "Shut off fuel at source" will be the first action for any leak. To further improve operating safety, this procedure should be used for all refueling operations. In addition, fuel flow should be turned on at the source, not at the nozzle.
- E. Item numbers referred to in this section are those used in Figure 5.

11.2 RISK ASSESSMENT - A risk assessment procedure based upon the hazard probability, as well as hazard severity may be required to establish priorities for corrective action and resolution of identified hazards. One example is the real hazard index; a numeric rank ordering of a mathematical combination arrived at by assigning numerical values to the severity category and probability level.

A. Hazard Probability - The probability that a hazard will occur during the planned life expectancy of the system can be described in potential occurrences per unit of time, event, population, item or activity. Assigning a quantitative hazard is generally not possible early in the design process. A qualitative hazard probability may be derived from research, and evaluation of historical safety data from similar systems.

Level	Descriptive word	Specific Individual Item	Fleet or Inventory
A (6)	Frequent	Likely to occur frequently	Continuously experienced
B (5)	Reasonably probable	Will occur several times in life of an item	Will occur frequently
C (4)	Occasional	Likely to occur sometimes in the life of an item	Will occur several times
D (3)	Remote	So unlikely, it can be assumed that this hazard will not be experienced	Unlikely to occur but possible
E (2)	Extremely Improbable	Probability of occurrence cannot be distinguished from zero	So unlikely it can be assumed that this hazard will not be experienced
F (1)	Impossible	Physically impossible to occur	Physically impossible

B. Hazard Severity - Hazard severity categories are defined to provide a qualitative measure of the worst potential consequences resulting from personnel error, environmental conditions, design inadequacies, procedural deficiencies, or system, subsystem or component failure/ malfunction.

Severity Category	Descriptive word	Results
I (4)	Catastrophic	May cause death or system loss
II (3)	Critical	May cause severe injury, or system damage
III (2)	Marginal	May cause minor injury, minor occupational illness, or minor system damage
IV (1)	Negligible	Will not result in injury, occupational illness, or system damage

C. Real Hazard Index (RHI) Matrix - (RHI = Hazard Severity X Probability Level)

HAZARD SEVERITY

<u>PROBABILITY LEVEL</u>	<u>HAZARD SEVERITY</u>			
		<u>I (4)</u>	<u>II (3)</u>	<u>III (2)</u>
A (6)	24	18	12	6
B (5)	20	15	10	5
C (4)	16	12	8	4
D (3)	12	9	6	3
E (2)	8	6	4	2
F (1)	4	3	2	1

General guidelines for required action.

RHI

1-8 No action required.

9-12 Special precautions required, investigate redesign.

13-24 Hazardous, redesign necessary or procedural control if redesign is impractical.

11.3 FAILURE MODES AND EFFECTS ANALYSIS (FMEA) – Refer to Figure 5 for component numbers mentioned in column one.

NR	COMPONENT	FUNCTION	FAILURE MODE	RESULT OF FAIL	HAZARD CATEGORY	HAZARD PROBABILITY	REAL HAZARD INDEX (RHI)	CORRECTIVE ACTION
1	Bumper (7)	Protects locking plate and nozzle body	Missing or torn	Possible locking plate damage	IV (1)	4 (C)	4	Visual Inspection
2	Locking Lug Retainer Plate (10)	Secures nozzle to aircraft receptacle	Deformed or cracked	Difficulty in connecting to aircraft	IV (1)	3 (D)	3	Visual Inspection
			Deformed or cracked	Improper seal resulting in fuel leak	II (3)	4 (C)	12	
			Broken	Nozzle released from aircraft receptacle resulting in fuel spill/spray	I (4)	3 (D)	12	
3	Locking Lug Retainer Screw (8)	Secures locking lug retainer plate to the nozzle body	Missing or broken (all)	Unit unusable	IV (1)	3 (D)	3	
			Missing or broken (5-2)	Nozzle released from aircraft receptacle under pressure resulting in fuel spill/spray	I (4)	3 (D)	12	
			Missing, loose or broken (1)	No effect	IV (1)	4 (C)	4	
			Loose (all-2)	Improper seal resulting in fuel leak	II (3)	4 (C)	12	
4	Retainer (9)	Provides proper nozzle/ receptacle alignment at connection	Cracked	No effect	IV (1)	3 (D)	3	Visual Inspection
			Broken or missing	Possible improper nozzle/receptacle connection resulting in fuel spill/spray	II (3)	3 (D)	9	
5	Locking Plate spring (11)	Maintains alignment plate in the locking position when disconnected	Missing (1)	No effect	IV (1)	3 (D)	3	
			Missing (2 or more)	Possible improper nozzle/receptacle connection resulting in fuel spill/spray	II (3)	3 (D)	9	
6	Nozzle Body (6)	Holds all components together	Cracked	Fuel leak	I (4)	3 (D)	12	Pressure test prior to use
7	Handle Grip(43)	Provides gripping surface for handle	Missing or worn	No effect	IV (4)	4 (C)	4	Visual Inspection
8	Handle Grip Bolt (41)	Holds handle grip in place and allows attachment of lanyards or bonding wires	Missing or loose	Cannot attach lanyard or bonding wire	IV (4)	4 (C)	4	Visual Inspection

NR	COMPONENT	FUNCTION	FAILURE MODE	RESULT OF FAIL	HAZARD CATEGORY	HAZARD PROBABILITY	REAL HAZARD INDEX (RHI)	CORRECTIVE ACTION
9	Handle Grip Washer (42)	Provides bearing surface for handle grip bolts	Missing or broken	No effect	IV (1)	4 (C)	4	
10	Interlock Ring/ Nose Seal Assembly (21)	Facilitates interface sealing between nozzle and receptacle	Nose seal torn or broken	Fuel leak	II (3)	4 (C)	12	Visual Inspection
		Seals poppet valve in nozzle body	Poppet seal torn or broken	Fuel leak	II (3)	4 (C)	12	Pressure test prior to use
		Prevents poppet valve from being open in disconnected condition	Interlock ring broken or badly worn.	Possible inadvertent opening of poppet valve resulting in fuel spray	I (4)	3 (D)	12	
11	Interlock Ring/ Nose Seal Thrust Washer (22)	Serves as bushing between interlock ring and nozzle body	Worn or torn	Additional force in attaching nozzle to aircraft	IV (1)	3 (D)	3	
12	Body/ Interlock Ring O-ring (23)	Seals between nozzle body and interlock ring	Worn or torn	Fuel leak	II (3)	4 (C)	12	Pressure test prior to use
13	Poppet (20)	Shuts off fuel flow	Cracked or broken	Fuel Spray	I (4)	3 (D)	12	Pressure test prior to use. Shut off fuel at source
			Missing	Fuel spray	I (4)	3 (D)	12	Pressure test prior to use
14	Poppet Thrust Washer (15 & 17)	Serves as rotational bearing between poppet and poppet insert	Worn or torn	No effect	IV (1)	3 (D)	3	
15	Poppet Insert (18)	Holds poppet to valve shaft	Cracked or broken	Poppet separation from nozzle resulting in fuel spray	I (4)	3 (D)	12	Pressure test prior to use
16	Poppet Bearing Ball (16)	Reduces metallic wear between poppet and receptacle valves	Broken or missing (1 to 5)	No effect	IV (1)	3 (E)	3	
			Broken or missing (6 or more)	Poppet separation from nozzle resulting in fuel spray	I (4)	2 (E)	8	Pressure test prior to use
17	Poppet Bearing Thrust washer (19)	Provides poppet ball bearing seats	Broken or missing	Poppet separation from nozzle resulting in fuel spray	I (4)	3 (D)	12	Pressure test prior to use
18	Poppet Ball Bearing Retaining Ring (14)	Secures Poppet ball bearing to Poppet Insert	Broken or missing	Poppet separation from nozzle resulting in fuel spray	I (4)	3 (D)	12	Pressure test prior to use
19	Cotter Pin (12)	Secures Poppet to Poppet shaft	Broken or missing	Poppet separation from nozzle resulting in fuel spray	I (4)	3 (D)	12	Pressure test prior to use
20	Poppet Shaft (32)	Connects poppet to handle assembly (in line with valve link)	Broken	Poppet valve opens resulting in fuel spray	I (4)	3 (D)	12	Pressure test prior to use Shut off fuel at source
			Bent	Difficult to open or close valve	III (2)	3 (D)	6	Pressure test prior to use Shut off fuel at source

NR	COMPONENT	FUNCTION	FAILURE MODE	RESULT OF FAIL	HAZARD CATEGORY	HAZARD PROBABILITY	REAL HAZARD INDEX (RHI)	CORRECTIVE ACTION
21	Valve Link (28)	Connects poppet valve to crank assembly (in line with valve shaft)	Broken	Poppet valve opens resulting in fuel spray	I (4)	3 (D)	12	Pressure test prior to use Shut off fuel at source
				Possible to open poppet valve inadvertently resulting in fuel spray	I (4)	3 (D)	12	
			Bent	Difficult to open or close valve	III (2)	3 (D)	6	
22	Valve Link Pin (31)	Connects valve shaft to valve link	Installed backwards	Cannot open valve fully	IV (1)	1 (F)	1	
			Missing or Broken	Poppet valve opens resulting in fuel spray	I (4)	3 (D)	12	Pressure test prior to use Shut off fuel at source
23	Crank Shaft (33)	Attaches valve assembly to crank handle	Bent	Difficult to open or close valve	III (2)	3 (D)	6	
			Broken	Poppet valve opens resulting in fuel spray	I (4)	3 (D)	12	Pressure test prior to use Shut off fuel at source
24	Valve Link Bolt (29)	Fastens valve link to crank shaft	Missing or broken	Poppet valve opens resulting in fuel spray	I (4)	3 (D)	12	Pressure test prior to use Shut off fuel at source
			Bent	Difficult to open or close valve	III (2)	3 (D)	6	
25	Valve Link Nut (25)	Fastens valve link bolt to crank shaft	Missing or broken	Valve link bolt may back out	I (4)	3 (D)	12	Pressure test prior to use Shut off fuel at source
26	Link Nut Cotter Pin (24)	Locks valve link nut	Missing or broken	Valve link nut may back out	I (4)	3 (D)	12	Pressure test prior to use Shut off fuel at source
27	Link/Crank Shaft Separation Washer (30)	Provides proper spacing between the link and handle shaft	Missing or Broken	No effect	IV (1)	2 (E)	2	
28	Crank Shaft Bearing (36 & 36A)	Prevents galling between crank shaft and nozzle body	Worn or torn	Additional force in attaching nozzle to aircraft	IV (1)	2 (E)	2	
29	Crank Arm	Facilitates actuation of nozzle valve	Missing or broken	Unit unusable	IV (1)	4 (C)	4	
			Bent	Difficult in use (binding)	IV (1)	3 (D)	3	
30	Crank Shaft/Arm Screw (26)	Fastens crank arm to crank shaft	Missing or Broken (2 or all)	Crank arm comes loose. Unit unusable	IV (1)	3 (D)	3	
			Missing or broken (1)	No Effect	IV (1)	4 (C)	4	
31	Crank Shaft O-ring (35)	Provides seal between body and crank shaft	Missing	Fuel spray	I (4)	3 (D)	12	Pressure test prior to use
			Torn or broken	Fuel Leak	II (3)	3 (D)	9	Pressure test prior to use

NR	COMPONENT	FUNCTION	FAILURE MODE	RESULT OF FAIL	HAZARD CATEGORY	HAZARD PROBABILITY	REAL HAZARD INDEX (RHI)	CORRECTIVE ACTION	
32	Crank Shaft washer (34)	Provides bearing between crank shaft and nozzle body	Missing, broken or excessively worn	Renders crank shaft O-ring nonfunctional resulting in fuel Leak	II	(3)	3 (D)	9	Pressure test prior to use
		Backs crank shaft O-ring	Missing or broken	Renders crank shaft O-ring nonfunctional resulting in fuel Leak	II	(3)	3 (D)	9	Pressure test prior to use
33	Crank Handle Knob (38)	Facilitates handle to actuate nozzle valve	Missing, broken or worn	Difficult in use	IV	(1)	5 (B)	5	
34	Crank Handle Knob Clamp (39)	Holds crank handle knob to crank arm	Missing or broken	No Effect	IV	(1)	2 (E)	2	
35	Crank Handle Knob Screw (37)	Fastens crank handle knob to crank arm	Missing or broken	Loss of crank handle knob. Difficult in use	IV	(1)	3 (D)	3	
36	Crank Handle Knob nut (40)	Fastens crank handle knob to crank arm	Missing or broken	Loss of crank handle knob. Difficult in use	IV	(1)	3 (D)	3	
37	Bonding Clip (4)	Provides sliding contact for electrical bonding between nozzle body and swivel joint	Missing or broken	Nozzle loses electrical continuity	III	(2)	3 (D)	6	
			Bent	Binding swivel	IV	(1)	3 (D)	3	
38	Swivel Ball Race	Provides seat for swivel balls	Missing	Renders swivel seal nonfunctional resulting in fuel spray	I	(4)	3 (D)	12	Pressure test prior to use
			Broken	Binding swivel	IV	(1)	3 (D)	3	
39	Swivel O-ring	Provides seal at swivel	Worn or torn	Fuel leak	II	(3)	3 (D)	9	Pressure test prior to use
			Missing	Fuel spray	I	(4)	3 (D)	12	Pressure test prior to use
40	Swivel Inlet Housing	Attaches refueling hose to nozzle	Cracked or broken	Fuel spray or leak	I	(4)	3 (D)	12	Pre-use visual inspection
41	Swivel bearing	Provides sliding sealing surface between nozzle body and swivel inlet tube	Missing or broken	Fuel spray or leak	I	(4)	3 (D)	12	Pre-use visual inspection
42	Swivel Inlet Housing O-ring	Provides seal at swivel	Worn or torn	Fuel leak	II	(3)	3 (D)	9	Pressure test prior to use
			Missing	Fuel spray	I	(4)	3 (D)	12	Pressure test prior to use
43	Swivel Retaining Balls (3)	Keeps swivel inlet tube attached to nozzle	Broken or galled	Difficulty in attaching nozzle to aircraft	IV	(1)	3 (D)	3	
			Missing (all)	Unit unusable; swivel tube will not stay attached	IV	(1)	2 (E)	2	
			Missing (25-38)	Fuel leak	II	(3)	3 (D)	9	Pressure test prior to use
			Missing (1-	No effect	IV	(1)	4 ©	4	

24)

NR	COMPONENT	FUNCTION	FAILURE MODE	RESULT OF FAIL	HAZARD CATEGORY	HAZARD PROBABILITY	REAL HAZARD INDEX (RHI)	CORRECTIVE ACTION
44	Swivel Retaining Ball Screw (1)	Provides access for swivel retaining balls. Allows balls to move freely in raceway	Missing	Loss of retaining balls	II (3)	3 (D)	9	Depends on number of balls missing (See item #43)
					IV (1)		4	
			Loose	Fuel Leak	II (3)	4 (C)	12	Depends on number of balls missing (See item #43), but less likely
45	Swivel Retaining Ball Screw O-ring (2)	Provides seal for retaining ball screw against nozzle body	Missing, broken or torn	Fuel leak	II (3)	3 (D)	9	Pressure test prior to use
46	Access Port Plug (5)	Provides access for apply pressure gauge or other accessories	Missing	Massive fuel spill	I (4)	3 (D)	12	Pressure test prior to use
								Visual inspection
			Loose	Fuel Leak	II (3)	3 (D)	9	Pressure test prior to use
47	Dust Cap (44)	Protects nozzle lugs and valve (when not in use)	Torn or missing	No effect	IV (1)	3 (D)	3	



Conveyance Systems Division
Carter Ground Fueling

671 W. 17th Street
Costa Mesa, CA 92627
Ph (949) 764-2200
Fax (949) 631-2673