



Powering Business Worldwide

Eaton Aerospace Business
Conveyance Systems Division
Carter® Ground Fueling

SM64200

February 2007

APPLICABLE ADDITIONAL MANUALS:

SM44315 Quick Disconnect Assy
SM44646 Hose End Control Valve
SM47013 Hose End Control Valve
SM60129-1 Hose End Control Valve
SM428MISC Miscellaneous Adapter Assemblies
SM427MISC Miscellaneous Adapter Assemblies
SM44642 60427 Type QD Assemblies
SM61154 Dry Break Disconnect Assy
SM64015 Ball Valve

Maintenance Manual

Pressure Fueling Nozzle
Standard Commercial Unit

Model 64200

TABLE OF CONTENTS

	PAGE
1.0 INTRODUCTION	3
2.0 EQUIPMENT DESCRIPTION	3
3.0 TABLE OF OPTIONS AND ORDERING INFORMATION	4
4.0 SAFETY INFORMATION.....	6
5.0 SPECIAL TOOLS	7
6.0 DISASSEMBLY	8
7.0 INSPECTION.....	9
8.0 REASSEMBLY	10
9.0 TEST	11
10.0 ILLUSTRATED PARTS CATALOG	12
FIGURE 1 - 64200 PARTS BREAKDOWN	15
FIGURE 2 64200 - OPTIONS.....	16
FIGURE 3, HOLDING BRACKET & STIRRUP HANDLE	17
FIGURE 4 - CONTINUITY CLIP INSTALLATION	18
FIGURE 5 - POPPET/COTTER PIN INSTALLATION	18
KITS.....	19

MAINTENANCE, OVERHAUL & TEST INSTRUCTIONS

CARTER PART NUMBER 64200 PRESSURE FUELING NOZZLE

1.0 INTRODUCTION

This manual furnishes detailed instructions covering the maintenance and overhaul of Carter Part Number 64200, Pressure Fueling Nozzle and its various options.

For the maintenance of options to the basic 64200 Pressure Fueling Nozzle, refer to Options Table, Section 3.0. This table will reference the service manual that should be used in the maintenance of each option.

2.0 EQUIPMENT DESCRIPTION

The Carter Ground Fueling part number 64200, Pressure Fueling Nozzle, is a 2 1/2 inch Pressure Fueling Nozzle that has been qualified to appropriate sections of the new SAE AS5877 Nozzle Specification released (or in the process of being released at the time of publication of this manual) to cover both commercial and military nozzles. Prior to its production release over 35 prototype nozzles were subjected to field evaluation at various environment locations around the world. Changes were then incorporated in the production version to agree with the suggestions and minor problems encountered by the using customers. The unit is designed to mate with adapters conforming to AS24484 (superseded MS24484) or equivalent. The 64200 is intended to replace the 64348 as the standard nozzle provided by Carter. The 64200 Nozzle is completely different from the previous 64348, although all mating accessories currently furnished on the 64348 will work on the 64200.

The major differences lie in the simplification in the design to remove parts, especially moving ones on the outside of the units. In addition, the interlock system, previously depended upon pins to mate with the aircraft adapter, has been revised to remove the pins. The interlock system is a part of the replaceable nose seal and will be updated with each replacement of the nose seal. This interlock system will prevent any wear of the slots, since it does not even use the slots, on the adapter. This is a great advancement in safety and cost savings. Aircraft adapter slots will not become worn because of the interlock system on the Carter nozzle. Reducing the wear of the slots reduces the chance of an accidental removal of

the nozzle with it open causing a fuel spill.

NOTE:

The 64200 interlock system depends upon the three lugs on the adapter being within the industry standard wear limits. Wear limits are specified in SAE document ARP5298 – Adapter Wear Limits. A copy can be obtained from Carter distributors or through Carter direct. See note later in this section regarding potential problems if adapter lugs are worn.

Other features of the new 64200 include:

- A six-slot arrangement is included for installing the nozzle onto the aircraft making it easier to install.

NOTE:

If the 64200 has been installed on an adapter that has lugs with wear beyond the industry standard limits it may be difficult or impossible to install on the next aircraft. To fix, simply hold nozzle onto adapter and turn it counter-clockwise to move locking ring into the correct position, then turn it clockwise to install onto adapter.

If this occurs it is suggested that the aircraft operator be told of the worn condition so that the adapter can be replaced at the earliest opportunity.

If the last adapter to which the nozzle was attached is on the refueling vehicle replace the adapter as soon as possible.

- Replaceable wear rings have been added to the various attaching options to improve the life of the swivel joint. (Note: All older options that attached to the previously qualified nozzles, 61429 and 64349, will mate with the newer 64200).

- The opening lever or handle has been repositioned to make it possible to attach to all aircraft and its operating direction has changed such that it is moved away from the aircraft, then opened, instead of into the aircraft as the older nozzles did. This makes it easier to open and close.
- Carrying handles on the 64200 are entirely of plastic eliminating the problems caused by the bending of the metal stick type handles used on previous Carter and competitor nozzles. They now act as shock absorbers when the nozzle is dropped reducing the damage caused by mishandling.

The basic nozzle would be procured under the part number 64200, which includes the dust cap. Other options that are available to build a nozzle to specific specifications are listed in the table shown in Section 3.0. The exploded views in the figures at the end of the manual include the various options available.

All older accessories, except the Bonding Cable, option D, utilized on the previously qualified nozzles, 61429 and 64349 will mate to the new nozzle.

3.0 TABLE OF OPTIONS AND ORDERING INFORMATION

The following table should be used to determine the service manual to be used in the maintenance, repair or replacement of parts designated by option letters to the basic 64200 nozzle.

OPTION LETTER	PART NUMBER	SERVICE MANUAL
A	44373-40	SM44315, SM61154 or SM64001
B	44373-60	SM44315, SM61154 or SM64001
C	44373-100	SM44315, SM61154 or SM64001
D	47235	SM64200
E	41599	SM64200
F	44646-**, 47013-**, or 60129-1** (Note 1)	SM44646 or SM47013
G	47403	SM64200
H	220870 (Note 2)	SM64200
J	44509	SM428MISC
K	22137	SM64200
P	47416	SM64200
Q	GTP-235-3/8	SM64200
R	47232	SM64200
S	47401	SM64200
T	44694	SM428MIS
U	47234	SM64200
V	47429	SM64200
X	No longer available, note 3	SM61154 or SM64001 (Note 3)
Y	47655	SM64200
1	47013-* (Note 1)	SM47013
2	44646-* (Note 1)	SM44646
3D, 3DE, 3H, 3J, 3K, 3L, 3M, 3N, 3P, 3R	64015	SM64015
4H, 4K, 4L, 4M, 4N, 4P	64001	SM64001
6H, 6K, 6L, 6M, 6N, 6P, 6Z	44315	SM44315
7H, 7K, 7L, 7M, 7N, 7P	61154	SM61154
9H, 9K, 9L, 9M, 9N, 9P, 9Z	40679	SM40679

- Notes:
1. The part number shown is not complete and must include the spring setting (35, 45 or 55) to achieve a complete number. The type of Hose End Control Valve used will depend upon whether a single or dual HECV, a dry break QD or ball valve is used.
 2. Option H is used only with 44646 HECV.
 3. Option X, Safety Clip on the Dry-Break or Thumb Latch QD, was available on earlier nozzles as an option. On newer nozzles starting with deliveries in mid-2001, it is standard equipment.

The part number of a complete nozzle consists of four basic parts as illustrated below.

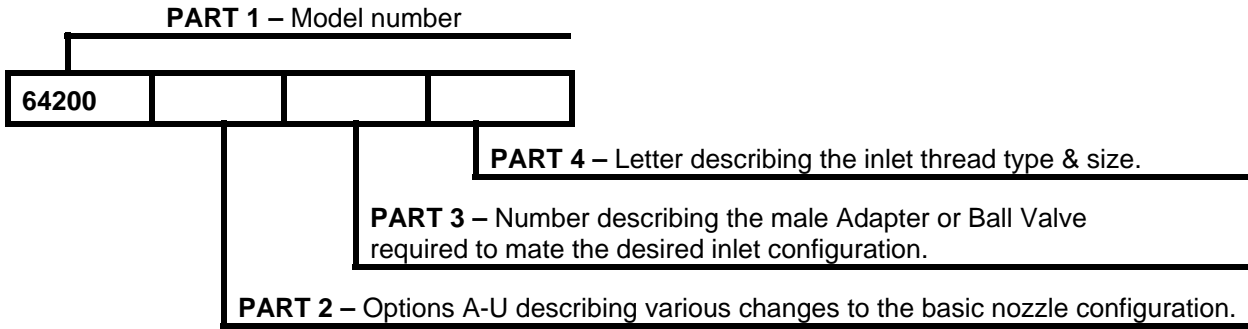

PART 2

The following options may be added as Part 2 of the part number as indicated above to order a unit to meet your requirements:

OPTION LETTER	DESCRIPTION	OPTION LETTER	DESCRIPTION
A	Adds 40-mesh Screen	J	Adds Flange Adapter to mate 60427 type accessories.
B	Adds 60-mesh Screen	K	Replaces standard operating handle with longer one.
C	Adds 100-mesh Screen	L	Replaces standard carrying handles with circular handle.
D	Adds Commercial style Bonding Cable	P	Adds Pressure Gauge with Protective Bracket
E	Adds Vacuum Breaker	Q	Adds Fuel Sampling QD
F1	Adds 15 psi Hose End Control Valve	R	Adds Nozzle Stowage Bracket
F3	Adds 35 psi Hose End Control Valve	S	Adds 45° Nozzle Stowage Bracket
F4	Adds 45 psi Hose End Control Valve	T	Adds male adapter to mate with Whittaker F582 QD.
F5	Adds 55 psi Hose End Control Valve	U	Changes Stick Handles to Stirrup Handles
F6	Adds 48 psi Hose End Control Valve	V	Replaces standard carrying handles with one used by the UK RAF.
G	Replaces standard handles with long handles.	W	Adds Military style Bonding Cable.
H	Adds Drag Ring to option F (44646 only).	Y	Adds Swivel Elbow

PART 3

One of the numbers below must be included, as Part 3, as indicated above, to specify the type of inlet configuration desired. The nozzle may be ordered with the inlet terminating in an adapter half only if desired. In this case leave Part 4 blank. If a female half, either quick disconnect, ball valve or dry break of some configuration is desired, Part 4 must be completed.

OPTION LETTER	DESCRIPTION	OPTION LETTER	DESCRIPTION
1	Adds 47013-* HECV with flanged inlet to accept flanged accessories.	J	Adds spanner wrench to operate the ball valve. Used only with option 3.
2	Adds 44646-* HECV with inlet to accept swivel style accessories.	R	Adds Allen Key to change the ball valve to defuel position.
3	Adds ball valve.	4	Adds male adapter to mate thumb latch type QD
Note: Options 3D-3R, J and R may be combined to get the desired end product.		6	Adds male adapter to mate with standard bayonet type QD
3D	Adds ball valve with Glass Inspection Cap.	7	Adds male adapter half to mate 61154 Dry Break.
3E	Adds ball valve with Drag Ring.	9	Adds male adapter half to mate with 60427 style QD.
3J	Adds ball valve with Defuel Key.		
3R	Adds ball valve with separate Spanner to operate unit and to remove stainer cap.		

PART 4

One of the following letters must be included as Part 4 as indicated above to specify the inlet thread and size:

OPTION LETTER	DESCRIPTION	OPTION LETTER	DESCRIPTION
H	Inlet thread – 2½" NPT	N	Inlet thread – 2" BSPP
K	Inlet thread – 2½" BSPP	P	Inlet thread – 2" NPT
L	Inlet thread – 3" NPT	Z	Inlet thread – 3" JIS used only with options 6 & 9.
M	Inlet thread – 3" BSPP		

Examples: 64200C6H – Nozzle with 100-mesh strainer and 2 ½" NPT inlet.

64200CF43DEH – Nozzle with 45 psi hose end control valve and ball valve with 100-mesh strainer, ball valve with glass inspection port, drag ring and 2½" NPT inlet.

4.0 SAFETY INFORMATION

The 64200 Nozzle is designed to overcome the interlock wear problems associated with previous Carter and Whittaker nozzles. The interlock system is not dependent upon pins in the nozzle engaging the slots in the aircraft adapter. The interlock system in the 64200 is internal and involves the body of the nozzle and the basic aluminum part of the nose

seal. The interlock system is refreshed with each replacement of the nose seal.

Safety is still a major concern when handling the nozzle. Certain areas of the nozzle should be inspected periodically to assure that the unit is safe to use.

4.1 OPERATING LEVER STOPS

The operating Lever (on-off control) (27A or B) opening and closing is controlled by

mechanical stops built into the Body (6) of the unit. This stop is also utilized as a wear strip to prevent wear of the Screws (26) that retain the Arm onto the nozzle. The Knob (38) is a sacrificial part that is also used for major part wear prevention.

Prior to each fueling of an aircraft it is recommended that the operator check the stop for the Arm to be sure it is functioning correctly. If the stop portion of the Body is worn down to where the Screws are being worn, then the nozzle should be replaced.

If the Knob is worn badly such that the Screws are in danger of being worn then the Knob should be replaced prior to the next refueling.

The connecting end of the nozzle should be checked to assure that the slots in the Body (6) and Retainer (9) are aligned before trying to connect to the aircraft or adapter. If the slots are not aligned place the nozzle onto the adapter as to connect and pressing in toward the adapter rotate the nozzle as far as possible in the clockwise direction. This will cam the retainer into the installation position to allow connection.

4.2 LEAKAGE DURING REFUELING

Any leakage from the nozzle or the mating joint with the aircraft should be cause for stopping the operation and the nozzle should be replaced. The following paragraphs describe the possible leakage paths with the 64200.

4.2.1 NOSE SEAL LEAKAGE

During the refueling operation the operator should note any leakage from any portion of the nozzle. Nose Seal (21) leakage will be apparent if there is fuel

dripping or otherwise present at the connection between the nozzle and the aircraft adapter. If any leakage is present during refueling, the operation should be stopped and the nozzle replaced. There are two possible leak paths, the Nose Seal (21) or the O-ring (23) around the Nose Seal. The nozzle should be overhauled to prevent future leakage.

4.2.2 OPERATING ARM LEAKAGE

If leakage is present from the area of the operating Arm (27A or B) then the O-ring (35) will have to be replaced. Refueling should not be continued if such leakage is present.

4.2.3 SWIVEL JOINT LEAKAGE

There are two possible leak paths from the swivel joint of the nozzle, from the O-ring (41) and the seal in the mating part or from the Gasket (2). The latter is highly unlikely. If leakage is present, stop refueling and replace the nozzle.

4.2.4 NOZZLE BODY PLUGS/ACCESSORIES

The 64200 has two accessories ports in the side of the body. These are shipped from the factory with pipe Plugs (5) installed. Other accessories are available either from Carter or other manufacturers that can be installed in one or both ports. Tightening the plugs or the accessory can normally stop leakage from either of these ports. Do not refuel with leakage from these devices.

Note!

Before installing another manufacturer's accessory in either port be sure that the item when installed does not interfere with the working mechanism inside the nozzle.

5.0 SPECIAL TOOLS

The following special tools are recommended for proper repair and or overhaul of the nozzle:

- S204451 - Standard three lug bayonet adapter flange or equivalent. (This item should have a handle of a sort mounted to two of the mounting holes to assist in turning it onto the nozzle).

- 6958CG or 6958CH Adapter or equivalent.
- 61607 Ball (10 & 11) Assembly Tool
- WL4680 Torque Wrench or Standard torque wrench is required for some disassembly and re-assembly. WL4680 includes several sockets for special usage on Carter products.

- 64200ST1 Poppet Adjustment Tool.

The above items are available from your Carter distributor.

6.0 DISASSEMBLY

6.1 Remove nozzle from end of hose at quick disconnect. Refer to appropriate service manual depending upon type of swivel disconnect utilized.

SERVICE MANUAL	DESCRIPTION
SM40679	60427 type QD
SM44315	Standard QD
SM61154	Dry Break QD
SM64001	Thumb Latch type QD
SM64015	Ball Valve
SM348MISC	Miscellaneous Adapters

required to allow 39 Balls (3) to fall out of hole. Remove accessory (refer to appropriate Service Manual). If Clip (4) is to be replaced, use a pair of needle nose pliers to grasp the existing part and pull it from the hole in the Body (6). See Figure 5. Clear the hole of any debris.

Remove Gasket (2) from Screw (1) and discard.

Remove O-Ring (41) from internal groove in the inlet of the Body (6) and discard.

Inspect the Ring (42); remove if necessary, for wear or damage. If not worn then leave it in place.

6.2 Screw (1) is a self-locking type screw that utilizes a nylon insert in the threads to affect the resistance required to provide the locking.

Note: Early versions of the nozzle may use a different Screw (1) that has a smaller thread. This thread in the Body (6) will not accept the Ball Tool 61607.

They are designed to be reused a number of times before losing their locking affectivity. Using a torque wrench, remove Screw (1) and Gasket (2) from lower half of Body (6), measuring the torque during removal. If the torque is less than 9.5 in lbs. (0.11-m kg) discard the screw and replace it with a new one during reassembly. Remove Balls (3), 39 each, from unit by use of the Ball Tool or by hand. On newer nozzles the Ball Tool can be used. If Ball Assy Tool 61607 is available, screw it into the boss from which Screw (1) was removed. Hold the nozzle such that the Tool is below the nozzle and rotate the accessory attached to the nozzle until all Balls (3) have been captured in the Tool. The correct amount of Balls (3) will be captured when the level of Balls (3) reaches the line scribed on the tube of the Tool. If the balls are to be removed by hand (without the tool) hold the bolt hole vertical (pointed down) and allow all ball bearings to fall through the bolt hole. Catch all balls in a container. Some rotation between the Body (6) and the attached accessory may be

6.3 To remove the Cover (51) or Bonding Cable (57) it is necessary to remove the appropriate Grip (45C) or Handle Assembly (46), (49), (52) or (94). If the Cover (51) and the Cable (57) are in good condition it is not necessary to remove either at this time. Leave them attached to the Body (6). If they are to be removed, the Screw (45A) or (43) should be removed with a torque wrench and the removal torque measured. This screw is a self-locking type and is designed to be reused several times before losing its locking capability. If the torque is less than 6.5 in-lbs. (0.078-m kg) discard it and replace it during reassembly.

6.4 Remove the Bumper (7) by prying up the thinner end with a wide bladed screwdriver and peeling it off the Body (6). If worn to a point that it no longer protects the Body (6) discard and replace.

6.5 If the interlock stowage Bracket (100) or (84) or Pressure Gauge Protective Bracket (88) is present, inspect to determine if it needs replacing. If it needs replacing remove Screws (86) or and Washers (87). Discard Bracket (100), (85) or (93).

6.6 Remove the six Screws (8) and Retainer (9).

6.7 Using an S204451 Adapter or any other standard 3-lug bayonet adapter, connect the nozzle to it and rotate nozzle clockwise to the open position. Remove nozzle off of adapter.

- 6.8 Remove Lock Plate (10) and four Springs (11).
- 6.9 Rotate operating Arm (27A or B) to open nozzle Poppet (19). Remove assembly. Check to see that assembly will swivel freely on Insert (17). If not then further disassembly is needed. If further disassembly is necessary continue on to 6.9.1 otherwise go to 6.10. Note: Unless another problem with the assembly has been noted do not disassemble it further.
- 6.9.1 Remove Retaining Ring using a small bladed screwdriver to capture the end of the ring and peel it out of the Poppet (19).
- 6.9.2 Remove Thrust Washers (15) and 22 Balls (16). Discard Thrust Washers (15). The balls are tiny so put them in a container for cleaning and future use.
- 6.9.3 Remove Insert (17) and Thrust Washer (18). Discard it.
- 6.10 Pull Nose Seal (21) from unit. If it has been in use for a year or more or if the rubber portion is damaged it should be discarded. This also refreshes the interlock system of the nozzle.
- 6.11 Remove and discard Thrust Washers (22) and O-ring (23).
- 6.12 Remove the Plug (5) or any accessory from Port A (Figure 2). This will provide access for later removal of other parts of the unit.
- 6.13 Remove and discard Cotter Pin (24). Rotate Link (28) to gain access to Pin (29) with an Allen wrench. Hold Pin (29) in place and unscrew Nut (25). Remove Pin (29). (Note that older links will be red in color while the newer ones will be natural stainless steel in color. Both are fine to use.)
- 6.14 The Shaft (32), Washer (30), Pin (31) and Link (28) can now be removed from the Body (6).
- 6.15 Remove Screws (26) and Arm (27A or B) with parts holding Knob (38) in place. Put aside for later disassembly. Note on older nozzles Bearing (36A) may not be present. Bearing (36) and Thrust Washer (34) may be used in lieu of Bearing (36A). The single Bearing (36A) is the latest configuration. The Bearing (36A) is flanged and must be removed from the inside of the Body (6). Regardless of which is present, remove and discard the bearing and thrust washer, if present.
- 6.16 The Bearing (36) Washers (34) and O-ring (35) can now be removed from the outside of the Body (6). The Bearings (36) may be difficult to remove. Care should be taken to not damage the bore of the Body (6) especially if a sharp tool is used for removal. It is recommended that a Teflon rod of $.690 \pm .002$ inches diameter ($17.526 \pm .051$ mm) be used for this purpose. Discard all of the parts removed from the shaft bore.
- 6.17 Remove Screw (37), Nut (40) and Washer (39) to replace Knob (38).
- 6.18 Note: Do not remove Pin (6A) from Body (6) for any reason unless it is damaged and is to be replaced. This is an integral part of the interlock system.
- 6.19 On option E - remove the Vacuum Breaker (20) only if replacement is required. The Vacuum Breaker (20) is not economical to repair and should be replaced, if needed, as a complete assembly. **Attempts to repair this unit may result in fuel spills.**
- 6.20 If Option P, Pressure Gage & Bracket Assembly (88) is present inspect to determine if it needs replacing. Replace only if there is a leak from the pipe thread where installed or if the gage is broken. If the Bracket (93) is worn thin remove and discard it. If it needs replacing remove Screws (91) and Washers (92) to move parts needing replacement.

7.0 INSPECTION

It is recommended that all O-rings (2), (23), (35) & (41), Thrust Washers (22) & (34), Nose Seal (21) & Cotter Pins (12) & (24), Knob (38) and Bearing (36) be replaced upon every overhaul. If Poppet Assembly (13) has been

disassembled then Thrust Washers (15) and (18) should also be discarded. Inspect all metal parts for dings, gouges, abrasions, etc. Use 320 grit paper to smooth and remove sharp edges. Replace any part with damage

exceeding 15% of local wall thickness. Use alodine 1200 to touch up bared aluminum. Precisely measure the following items. Replace any part that exceeds the identified maximum or minimum wear limits:

- Both holes in item 28 Link - .196 inch (4.98 mm) diameter max. & .318 inch (8.08 mm) diameter max.
- Hole in item 32 Shaft – .198 inch (5.03 mm) diameter max.
- Bearing diameter of item 31 Pin - .186 inch (4.70 mm) diameter min.
- Shaft of the Shaft Assembly (33) – No part of it shall be less than .621 inch (15.77 mm).
- Interlock Plate (10) – Visually check for wear on the corners of the tabs protruding from the outer diameter. If the corners are rounded off, replace this part.
- Wear Ring (42) – If the diameter of the wire is less than 0.075 inches (1.905 mm) at any place around the major

diameter or there are obvious worn or flat spots replace it.

- Retainer (9) – Carefully inspect for any cracks in the part. Replace as needed.
- Inspect Bracket (100), (85) or (93) if present for wear that will cause the item to be non-functional.
- Measure the larger diameter of item 29 Pin next to the head in at least two opposing directions. The larger diameter should not be less than 0.298" (7.60 mm).

If it is at this diameter or less, it has to be replaced. Characteristic wear on the older, softer pin results in an elliptical shape rather than a diameter. This tends to make the nozzle more difficult to close and results in possible leakage when it is closed.

- If present inspect Drag Ring (72) and the adjacent HECV. If the ring is worn to a point where the HECV body is being dragged, replace the ring.
- If present inspect Gage (89) for damage and replace if needed.

8.0 REASSEMBLY

8.1 Reassemble in reverse order of disassembly (Refer to Figure 2), observing the following:

8.1.1 Make certain all components are clean and free from oil, grease, or any other corrosion resistant compound on all interior or exterior surfaces. Wash all parts with cleaning solvent, and dry thoroughly with a clean, lint-free cloth or compressed air.

WARNING:

Use cleaning solvent in a well-ventilated area. Avoid breathing of fumes and excessive solvent contact with skin. Keep away from open flame.

DO NOT use any form of grease on Balls (3) and be certain to install proper number of balls in each hole of Body (6) and collar assembly. Count the number of Balls (3) to be sure that a total of 39 are to be replaced. Also make sure that Clip (4) is installed properly to maintain continuity through the unit. Refer to Figure 5 for installation information.

NOTE: A light coat of petroleum jelly can be applied to all O-rings, springs, and non-locking screws for ease of installation.

8.1.2 When installing Pin (31) in place it can be inserted into the Link (28) and Shaft (32) outside of the body and held in place by a small piece of tape while assembling into the unit. Be sure to remove the tape afterwards. One can also hold the pin in place with one finger while inserting.

Reinstall the Plug (5) after completing assembly of the internal parts of the nozzle. **NOTE:** The Plug (5) has a sealant already in place and can be reused for several times. If Teflon tape is used on reinstallation, do not utilize more than 1 1/2 wraps of tape. Excessive use of tape could lead to the cracking of the Body (6).

8.1.3 If the Poppet Assembly (13) was disassembled a coating of petroleum jelly and the use of tweezers to install the small Balls (16) will make

the job easier. There are 22 of the balls.

8.1.4 When reinstalling the Nose Seal (21) care should be taken to position it with two lugs placed within the large grooves in the Body (6) and the flat part of the tongue of the nose seal up against the Link (28) when the operating Arm (27A or B) is in the nozzle open position. Seat the Nose Seal (21) into the Body (6).

8.1.5 The standard poppet adjustment tool used on previous Carter nozzles will not work on the 64200. A good starting point in adjusting the poppet is to bottom the poppet onto the Shaft (32) with the nozzle open, then back it out approximately 1.75 turns. Once the adjustment is made, rotate the Poppet toward the tightening direction until the next slot in the Poppet (19) is in line with the hole in the Shaft (32). Insert the Cotter Pin (12) but do not bend the ends at this time. Close the nozzle and check the adjustment with the poppet adjustment tool. If the adjustment is not within the "go-no-go" range, remove the cotter pin and re-adjust until the correct dimension is achieved. Then bend over the ends of the Cotter Pin (12) to retain in place in accordance with Figure 5. Note it is important that the correct length of Cotter Pin (12) is utilized for the assembly

8.1.6 Use the adapter to rotate the nose seal counter-clockwise to the nozzle-closed position.

8.1.7 Install Plate (10) and Springs (11) noting that the four indentations on the plate must fit into each of the four springs.

8.1.8 Hold the Plate (10) in position and install the Retainer (9) with the six

Screws (8). These screws should be torqued to 50 in-lbs. (0.58 m-kg).

8.1.9 Reinstall the Bumper (7).

8.1.10 If the Grip (45C), (48), (50) or Handle Assembly (52) or (94) requires replacing due to wear or the replacement of the Cover (51), the new Grips (45C), (48), (50) or Handle Assembly (52) or (94) shall be reinstalled using the appropriate screws and washers.

8.1.11 Note that Bearing (36A) must be installed into the handle shaft hole in the Body (6) from the inside and must be seated in place prior to installing the Crank Shaft Assembly (33).

8.2 **CRITICAL ASSEMBLY NOTE:** Where applicable on assembly of an accessory to this nozzle, the following torquing sequence and values for the mating to the nozzle should be used:

8.2.1 The six screws accompanying the accessory should be torqued to 75-79 in-lbs. (8.5-9 N-m). Tighten all screws to bottom the heads against the flange without over tightening.

8.2.2 Then start with one screw, mentally numbered "1" working in a clock-wise pattern, tightening approximately to half of the end torque values above. Skip across to screw "4" followed by "6", "2", "5" and finally "3".

8.2.3 Repeat the tightening at the final torque value above in the same pattern.

8.3 If Gage (89) is to be replaced use a maximum of 1 ½ wraps of Teflon tape on the Bushing (90) when installing into Body (6) to prevent cracking the boss wall. The Gage (89) can be installed in either port.

9.0 TEST

9.1 The following test procedures will be accomplished after overhaul:

9.2 Test conditions

Test media shall be JP-4, Jet A or odorless kerosene, commercial solvent 140.

9.3 Functional Test

9.3.1 The nozzle shall be inserted and locked into a test adapter, Carter 6958CG or CH or equivalent and the nozzle valve actuated by use of the crank Arm (27A or B) from the fully closed to fully open position a minimum

of five times. There shall be no evidence of binding or excessive force required for valve actuation.

inlet to five psi and hold for one-minute minimum. There shall be no evidence of external leakage from the nozzle.

9.4 Leakage Test

9.4.2 Repeat the leakage test at 60 psi and 120 psi.

9.4.1 With the nozzle outlet in the normal open position and the test adapter outlet closed, pressurize the

9.4.3 Close and disengage the nozzle and repeat 9.4.1 and 9.4.2.

10.0 ILLUSTRATED PARTS CATALOG

Table 1.0 tabulates the parts and sub-assemblies comprising the 64200 Pressure Fueling Nozzle. The item

numbers of the table are keyed to the exploded views of the nozzle diagrammed in Figures 1 through 4.

TABLE 1.0

The following table presents all items used in the basic 64200 Nozzle and its possible options. The column headed by "Spares/10 Units/Yr." represents our best estimate as to the spare parts needed to support 10 basic nozzles (and some of its options) for a one-year period. All items that show a need for 10 or more items are provided in the appropriate overhaul kit.

Item No.	Part Number	Description	Qty / Assy	Used on Option	Spares/10 Units/Yr.
1	220484	Screw	1	All	-
2	MS29512-03	Gasket	1	All	10
3	221075	Ball	39	All	-
4	209853	Clip, continuity	1	All	-
5	210388	Plug	2	All except E	-
6	47367	Body Assembly	1	All	-
6A	.156-.500LDP	Pin (Not a spare part)	1	All	-
6B	221311	Body (Not a spare part)	1	All	-
7	220999	Bumper	1	All	5
8	NAS1351-3-8P	Screw	6	All	-
9	220995	Retainer	1	All	-
10	221120	Plate, Interlock	1	All	-
11	C0240-020-0810S	Spring, Interlock	4	All	-
12	GF24665-368	Cotter Pin	1	All	10
13	47271	Poppet Assembly	1	All	-
14	RRN-100S	Ring, Retaining	1	All	-
15	91124A110	Washer, Thrust	1	All	10
16	GF19060-508	Ball	22	All	-
17	221008	Insert, Poppet	1	All	-
18	95606A260	Washer, Thrust	1	All	10
19	221010	Poppet	1	All	-
20	41599	Vacuum Breaker	1	E	-
21	47368	Nose Seal, Interlock Assy	1	All	10
22	221011	Washer, Thrust	2	All	20
23	M25988/1-148	O-ring	1	All (STD)	10
	201201-148	O-ring (alternative – see Note 11)	1	All (Not STD)	10
24	GF24665-1013	Cotter Pin	1	All	10
25	GF320C4	Nut	1	All	-
26	221012	Screw	3	All	-
27A	221017	Arm, Crank (Std)	1	All except K	2
27B	221317	Arm, Crank (Long)	1	K	2

Item No.	Part Number	Description	Qty / Assy	Used on Option	Spares/10 Units/Yr.
28	220994	Link	1	All	-
29	221014	Pin, Crank	1	All	-
30	5702-240-30Z2	Washer	1	All	-
31	D9-437	Pin	1	All	-
32	221005	Shaft	1	All	-
33	47209	Shaft Assembly, Crank	1	All	-
34	95606A210	Washer, Thrust	2	All	20
35	MS29513-208	O-ring	1	All	10
36	10L12-D	Bearing (on older units)	1	All	10
36A	10L14-F	Bearing, Flanged	1	All	10
37	GF24693C296	Screw		All	2
38	221019	Knob	1	All	10
39	221015	Washer	1	All	-
40	90044A029	Nut	1	All	2
41	M25988/1-235	O-ring	1	All	10
42	220893	Ring, Wear	1	All	2
45	47233-1	Handle Assembly, Std.	2	All except G & U	10
45A	GF16997-97L	Screw	2	All except U	-
44	GF960C616	Washer	2	All except U	-
45C	221020-1	Grip, standard	2	All except G & U	10
46	47429	Handle Assy, UK Style	2	V	-
43	221691	Screw	2	V	-
44	GF960C616	Washer	2	V	-
47	221566	Handle Extension	2	V	-
48	207808	Handle, Bicycle Grip	2	V	-
49	47233-2	Handle Assy, Long	2	G	
45A	GF16997-97L	Screw	2	G	-
44	GF960C616	Washer	2	G	-
50	221020-2	Handle, Long	2	G	
51	221026	Cover, Dust	1	All	5
52	47234	Stirrup Handle Assembly	1	U	-
53	221001	Handle	1	U	4
54	221003	Support	4	U	-
55	GF16997-103	Screw	2	U	-
56	5851-17	Washer	2	U	-
57	47235	Cable, Bonding	-	D	-
58	64200	Nozzle, Basic	1	All	-
59A	44646-*	Hose End Control Valve (Note 1)	-	F1, F3, F4 F5, F6	-
59B	47013-*	Hose End Control Valve (Note 1)	-	F1, F3, F4, F5, F6	-
59C	60129-1*	Hose End Control Valve (Note 1)	-	F1, F3, F4 F5, F6	
60	44316	Adapter - (Note 2)	-	6	-
61	44373-**	Screen Assy - (Note 2)	-	A, B, C	-
62	44317-*	Adapter - (Note 2)	-	6	-

Item No.	Part Number	Description	Qty / Assy	Used on Option	Spares/10 Units/Yr.
63	44694	Adapter – mates Whittaker QD (Note 3)	-	T	-
64	44185	Short Male Adapter – for use with option F only (Note 4)	-	4, 7	-
65	44697	Male Adapter – for use without option F only (Note 4)	-	4,7	-
66	64001*	Female QD (Note 7)	-	4	-
	61154*	Female Dry Break QD (Note 7)	-	7	-
67	210641	Clip, Safety – used with options 4 or 7 only.	-	4, 7	-
68	43046	Male Adapter Assy – for use with option F only (Note 5)	-	9	-
69	41767-*	Screen Assy for use with option 9. (Note 5)	-	9	-
70	43108-*	Female QD (Note 5)	-	9	-
71	64015*	Ball Valve (Note 6)	-	3H, 3L, 3P	-
72	220870	Drag Ring (for use with option F only)	-	H	10
73	44509	Male Adapter – 60427 Flange	-	J	-
74	47655	Swivel Elbow	1	Y	-
75-79	Left intentionally blank				
80	221617	Ring, Backup	1	All	1
81	GTP-235-3/8	Fuel Sample QD	1	Q	-
82-83	Left intentionally blank				
84	47401	45° Nozzle Stowage Bracket Assy.	1	S	-
85	221534	Bracket	1	S	-
86	GF16997-60L	Screw	2	S	-
87	GF960C416	Washer	2	S	-
88	47416	Pressure Gauge/Protective Bracket	1	P	-
89	80673	Gauge	1	P	2
90	5406-06-02	Reducer Bushing	1	P	-
91	GF16997-60L	Screw	2	P	-
92	GF960C416	Washer	2	P	-
93	47415	Bracket	1	P	-
94	47488	Handle Assy, Circular	1	L	-
95	207816	Grip, Circular	1	L	-
96	221347	Handle	2	L	-
97	GF960C616	Washer	2	L	-
98	GF16997-97L	Screw	2	L	-
99	47499	Ground Cable Assy	1	W	-
100	47232	Holder Bracket Assy	1	R	-

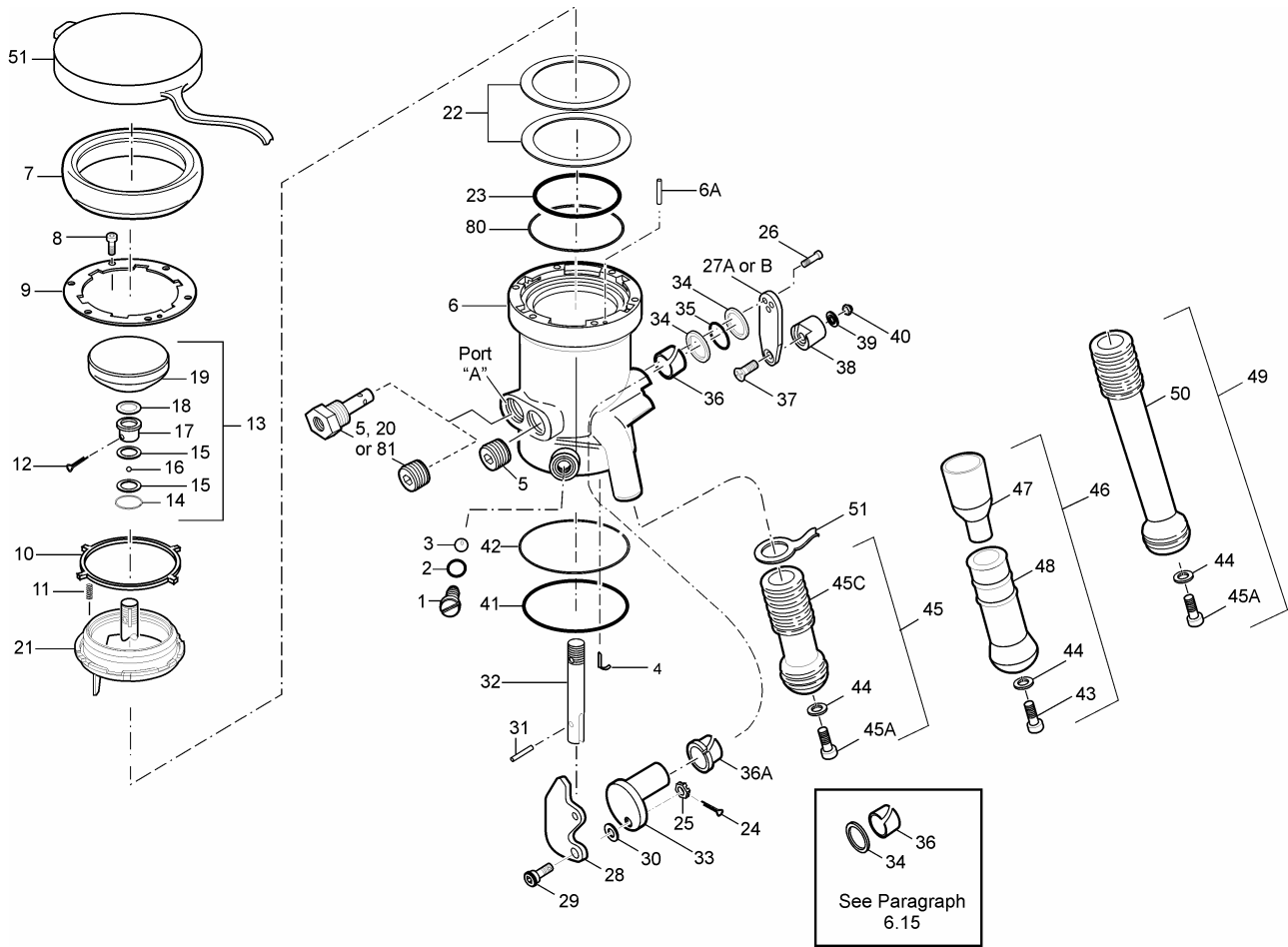

FIGURE 1
64200 PARTS BREAKDOWN

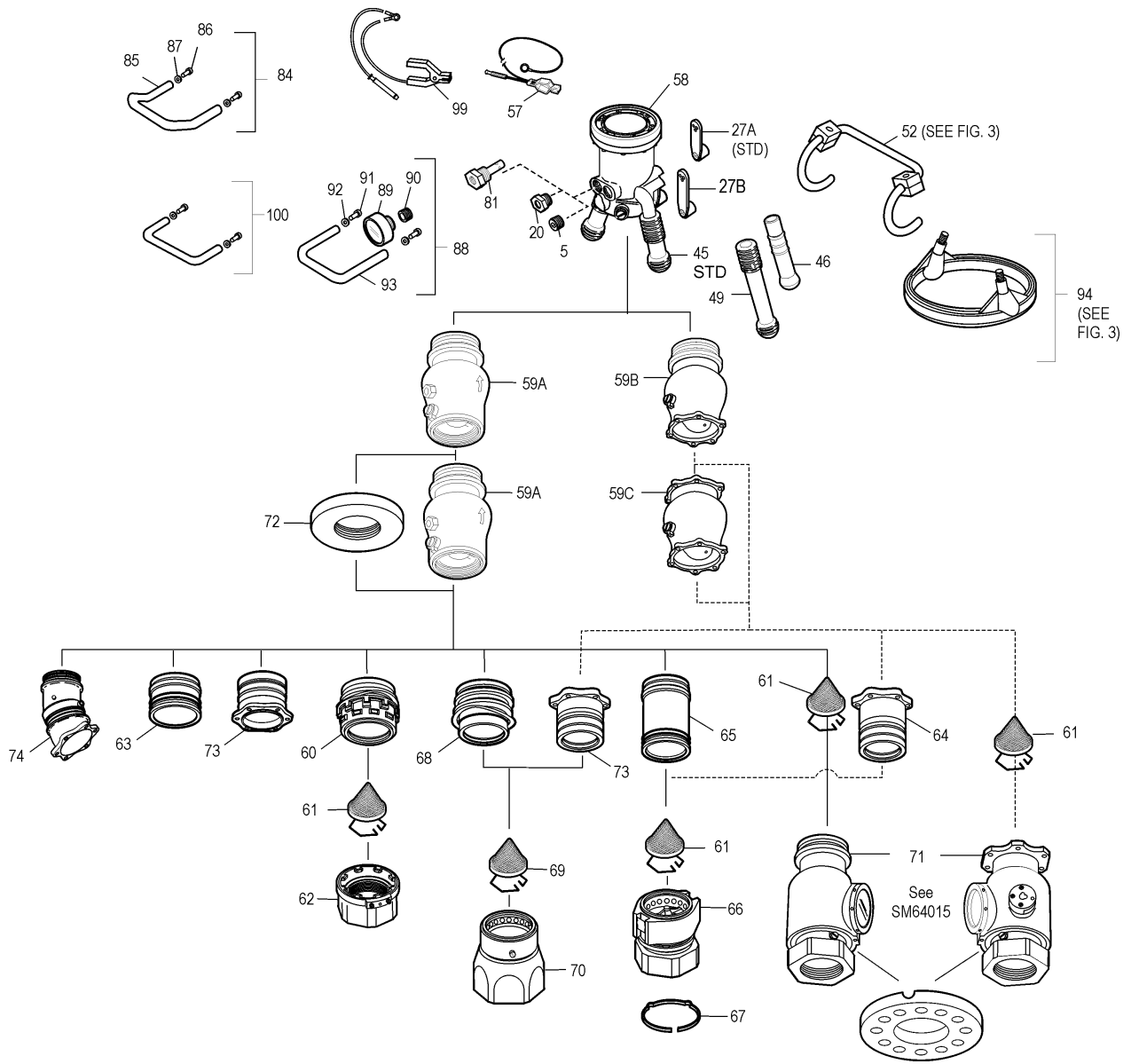

FIGURE 2 - 64200 OPTIONS

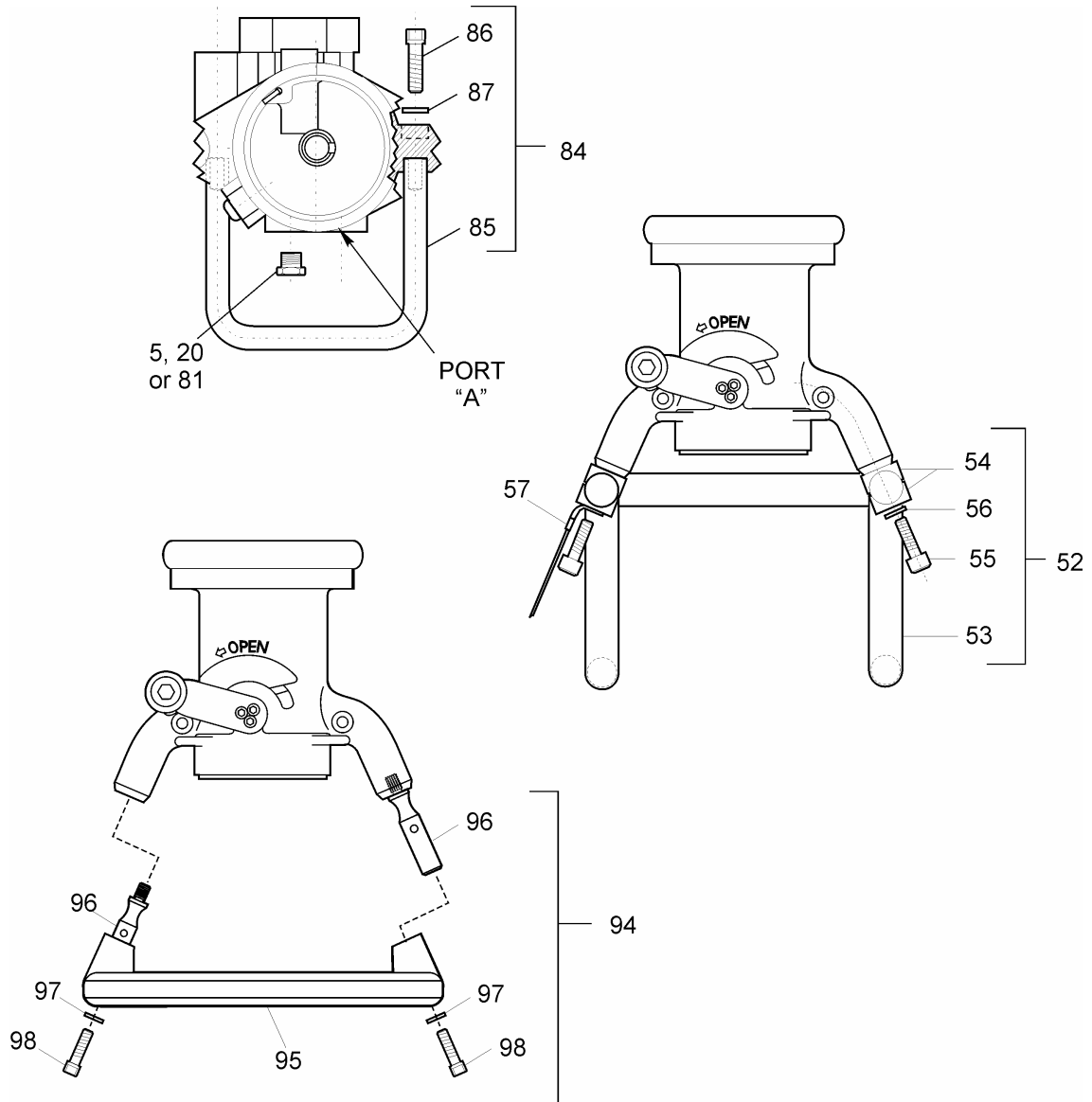

FIGURE 3

Holding Bracket, Circular and Stirrup Handle Installations

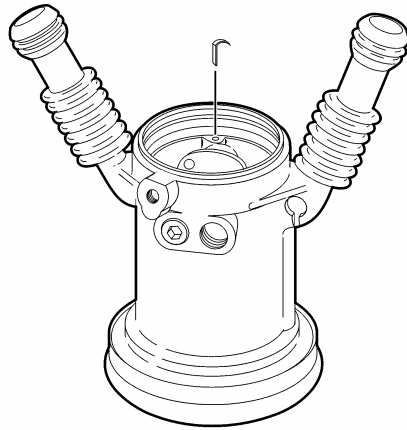

FIG. 4A
CONTINUITY CLIP INSTALLATION (4)

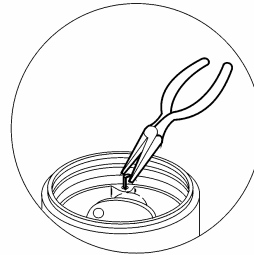
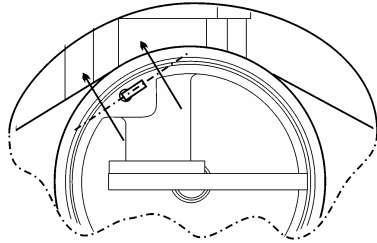

FIG. 4B
REMOVING CLIP (4)



OVERHEAD VIEW

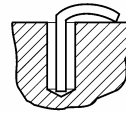

FIG. 4C
CORRECT CLIP INSTALLATION (4)

CONTINUITY CLIP INSTALLATION

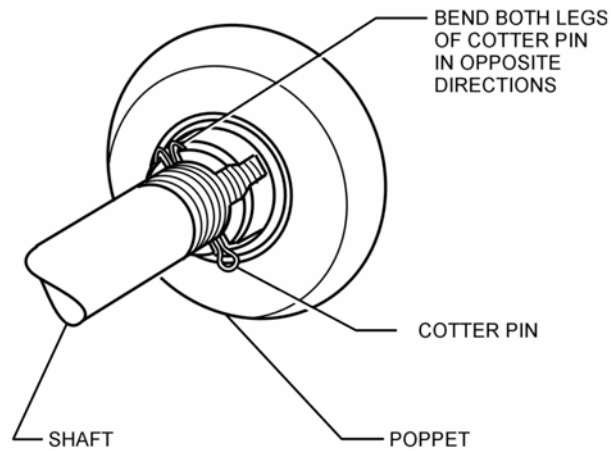

FIGURE 5 – POPPET/COTTER PIN INSTALLATION

TABLE 2.0

KITS – Kits provided by Carter are a more economical way to obtain recommended parts to overhaul or repair a unit. They also insure that genuine Carter parts are used in such repairs. The following kits are recommended for the various options noted and their content is based on experience. If any customer desires a special kit simply ask for it with the part numbers desired in the kit and the quantity and it will be made available. The kit contents shown in this document may not necessarily be the latest. Service manuals are changed on an irregular basis and may not be as up to date as kit drawings used to produce them. If a kit ordered is different than that shown in this document the content shipped will be in accordance with the latest production drawings.

Kit Part Number	Description	Kit Contents – Items from Table 1
KD64200-1	To maintain the basic nozzle only	Items 2, 4, 7, 12, 15, 18, 21-24, 34-36A, 38, 41 & 45C (Note some parts may not be needed on every overhaul. See Note 9.
KD64200-2	To maintain option 6 QD only (44315-*)	207807 Seal, 210174-337 Quad-Ring, M25988/1-040 O-ring & M25988/1-145 O-ring. See Note 9.
KD64200-3	To maintain option 7 dry-break QD only (61154*)	201201-233 O-ring, 207807 Seal, 209976-1 Wear ring, 209976-2 Wear ring, 221266 O-ring & M25988/1-040 O-ring. See Note 9.
KD64200-4	To maintain option 9 QD only (40679)	201201-231 O-ring, 207807 Seal, & M25988/1-040 -ring. See Note 9.
KD64200-5	To maintain option F with 44646 HECV. This kit is identical to KD44646-1 and if ordered separately, replace with KD44646-1.	Items 2, 4 & 207807 Seal, 220724-007 Quad-ring, 23893 Seal, 24059 Spacer, 24085 Seal, 600-001-10 Seal, LP515-8R7 Screw, LP526C1024R8 Screw, M25988/1-040 O-ring, M25988/1-235 O-ring, MS29513-126 O-ring, MS29513-147 O-ring & MS29513-229 O-ring. See Note 10.
KD64200-6	To maintain option F with 47013 HECV. This kit is identical to KD47013-1 and if ordered separately replace with KD47013-1.	207807 Seal, 220724-007 Quad-ring, 23893 Seal, 24059 Spacer, 24085 Seal, 600-001-10 Seal, LP515-8R7 Screw, LP526C1024R8 Screw, M25988/1-040 O-ring, MS29512-03 Gasket, MS29513-126 O-ring, MS29513-147 O-ring & MS29513-229 O-ring. See Note 10.
KD64200-7	To maintain option F with 60129-1 HECV this kit is identical to KD60129-1 and if ordered separately replace with KD60129-1.	201201-151 O-ring, 220724-007 Quad-ring, 23893 Seal, 24059 Spacer, 24085 Seal, 600-001-10 Seal, LP515-8R7 Screw, LP526C1024R8 Screw, MS29513-126 O-ring, MS29513-147 O-ring & MS29513-229 O-ring. See Note 10.
KD64200-8	To maintain option 3 ball valve (64015*)	209853 Clip, 207807 Seal, M25998/1-040, 201201-151, MS29513-111, MS29513-149 & MS29513-155 O-rings, 220068 Seal & MS29512-03 Gasket.
KD64200-9	To maintain a basic nozzle without replacing the grips.	Items 2, 4, 7, 12, 15, 18, 21-24, 34-36A, 38 & 41 (Note some parts may not be needed on every overhaul. See Note 9.
KD64200-90	To replace worn crank pin.	Items 24, 29, & 42. One should use this kit in conjunction with either a -1 or -9 kit.

Notes:

1. Refer to SM44646, SM60129-1 and 47013, as appropriate, for detail information. * Add pressure rating to part number to complete it. The type of hose end control valve used depends upon the rest of the options ordered.
2. Refer to SM44315 for detail information. On screen add mesh size 40, 60 or 100 in lieu of "***" to complete part number. On 44317-* add correct dash number (1-6) to complete part number.
3. Refer to SM349MISC for detail information.
4. Refer to SM64001 or SM61154 for detail information.
5. Refer to SM40679 for detail information.
6. Refer to SM64015 for detail information.
7. Refer to SM64001 or SM61154 for detail information.
8. All part numbers beginning with "GF" are interchangeable with those beginning with either "AN" or "MS". If three numbers follow the "GF" it is interchangeable with an "AN" part; otherwise it is interchangeable with an "MS" part of the same number.
9. Kits so noted can be combined, e.g. 64200-1-2 to obtain complete kit to fit the particular nozzle in use. However -2 through -4 are exclusive and only one can be used in any one-part number.
10. These kits are designed to allow one to order a combination kit as noted in note 9 above only. If either the KD64200-5, -6 or -7 Kits are to be ordered use KD44646-1, KD47013-1 or KD60129-1 respectively.
11. Item 23 O-ring is made of flurosilicon (blue in color) to facilitate closure of the poppet. This material is softer and does not swell when exposed to fuel. Due to its softer makeup, it also wears faster than Nitrile compounds. A suitable alternative would be Carter's 201201-148, which is a low swell Nitrile compound that will wear longer but will present a larger closure force. The use of a standard Nitrile O-ring will lead to much greater closure forces and not present a significant increase in life. It is not recommended for these reasons. The basic nozzle was tested in accordance with the latest SAE Commercial and Military Specification AS5877 with the blue O-ring and it passed without a problem. This entailed several thousand connections and opening and closing cycles and should represent months of service.
12. A kit that will include the harder 221014 Pin and other parts needed to install it is now available as KD64200-9.

Conveyance Systems Division
Carter Ground Fueling
671 West 17th Street
Costa Mesa, CA USA 92627-3605
Ph: (949) 764-2200
Fax: (949) 631-2673



